

**TECHNICAL MANUAL**

**ORGANIZATIONAL MAINTENANCE MANUAL  
ELECTRONIC CIRCUIT PLUG-IN  
UNIT TEST SET TS-3317 EQUIPMENT MAINTENANCE**

**EXPANDED TROUBLESHOOTING  
(LOGIC DIAGRAMS)**

**GUIDED MISSILE AIR DEFENSE SYSTEM  
AN/TSQ-73**

---

**HEADQUARTERS, DEPARTMENT OF THE ARMY**

**3 DECEMBER 1982**

CHANGE

No. 2

HEADQUARTERS  
DEPARTMENT OF THE ARMY  
Washington, DC, 30 May 1984

Organizational Maintenance Manual: Electronic Circuit Plug-In Unit Test Set TS-3317

Expanded Troubleshooting (Logic Diagrams)

**GUIDED MISSILE AIR DEFENSE SYSTEM AN/TSQ-73**

TM 9-1430-655-20-9-3, 3 December 1982, is changed as follows:

1. Remove old pages and insert new pages as indicated below. New or changed material is indicated by the applicable change number, i.e., Change 1, at the bottom of the page adjacent to the page number. Revised text will have a vertical bar in the margin next to the changed area. Revised illustrations will have a suffix change letter added to the identification number.

Remove Pages  
A(B blank)  
i and ii  
FO-18 (sheet 1)

Insert Pages  
A(B blank)  
i and ii  
FO-18 (sheet 1)

2. File this change sheet in front of the publication for reference.

By Order of the Secretary of the Army:

**JOHN A. WICKHAM, JR.**  
*General, United States Army*  
*Chief of Staff*

Official:

**ROBERT M. JOYCE**  
*Major General, United States Army*  
*The Adjutant General*

Distribution:

To be distributed in accordance with DA Form 12-32, Section III, Organizational Maintenance requirements for AN/TSQ-73 Missile System.

CHANGE

No. 1

HEADQUARTERS  
DEPARTMENT OF THE ARMY  
Washington, DC, 30 November 1983

Organizational Maintenance Manual: Electronic Circuit Plug-In Unit Test Set TS-3317

Expanded Troubleshooting (Logic Diagrams)

**GUIDED MISSILE AIR DEFENSE SYSTEM AN/TSQ-73**

Current as of 2 May 1983

TM 9-1430-655-20-9-3, 3 December 1982, is changed as follows:

1. This change should not be posted until MWO-9-1425-655-50-1 has been accomplished.
2. Remove old pages and insert new pages as indicated below. New or changed material is indicated by the applicable change number, i.e., Change 1, at the bottom of the page adjacent to the page number. Revised text will have a vertical bar in the margin next to the changed area. Revised illustrations will have a suffix change letter added to the identification number.

Remove Pages

A/(B blank)  
i and ii  
FO-1  
FO-18 (3 sheets)

Insert Pages

A/(B blank)  
i and ii  
FO-1  
FO-18 (3 sheets)

3. File this change sheet in front of the publication for reference.

By Order of the Secretary of the Army:

**JOHN A. WICKHAM, JR.**  
*General, United States Army*  
*Chief of Staff*

Official.

**ROBERT M. JOYCE**  
*Major General, United States Army*  
*The Adjutant General*

Distribution:

To be distributed in accordance with DA Form 12-32, Section III, Organizational Maintenance requirements for AN/TSQ-73 Missile System.

**WARNING**

**DANGEROUS VOLTAGE**

is used in the operation of this equipment

**DEATH ON CONTACT**

may result if personnel fail to observe safety precautions

Never work on electronic equipment unless there is another person nearby who is familiar with the operation and hazards of the equipment and who is competent in administering first aid. When the technician is aided by operators, he must warn them about dangerous areas.

Whenever possible, the power supply to the equipment must be shut off before beginning work on the equipment. Take particular care to ground every capacitor likely to hold a dangerous potential. When working inside the equipment, after the power has been turned off, always ground every part before touching it.

Be careful not to contact high-voltage connections when installing or operating this equipment.

Whenever the nature of the operation permits, keep one-hand away from the equipment to reduce the hazard of current flowing through vital organs of the body.

**WARNING**

**Do not be misled by the term "low voltage." Potentials as low as 50 volts may cause death under adverse conditions.**

EXTREMELY DANGEROUS POTENTIALS

greater than 500 volts exist in the following units:

Display console high voltage power supply

Display console CRT

**WARNING**

**For emergencies requiring immediate shutdown of system power, press SYSTEM POWER OFF switch located on power cabinet power transfer unit. Observe that SYSTEM POWER ON indicator light goes off.**

**a/(b blank)**

**LIST OF EFFECTIVE PAGES**

Insert latest change pages, dispose of superseded pages in accordance with applicable regulations.

**NOTE**

**The portion of the text affected by the latest change is indicated by a vertical line in the outer margins of the page.**

Dates of issue for original and change pages are:

Original ..... 0 ..... 3 Dec 82  
 Change ..... 1 ..... 30 Nov 83

Change.....2.....30 May 84

Page No.	*Draft Change
a .....	0
b Blank .....	0
A .....	2
B Blank .....	2
i .....	2
ii-v.....	0
vi Blank.....	0
FO-1 .....	1
FO-2 .....	0
FO-3 .....	0
FO-4 .....	0
FO-5 .....	0
FO-6 (5 Sheets) .....	0
FO-7 (2 Sheets) .....	0
FO-8 .....	0
FO-9 (2 Sheets) .....	0
FO-10 .....	0
FO-11 (8 Sheets) .....	0
FO-12 (3 Sheets) .....	0
FO-13 .....	0
FO-14 (2 Sheets) .....	0
FO-15 (7 Sheets) .....	0
FO-16 .....	0
FO-17 .....	0
FO-18 (Sheet 1) .....	2
FO-18 (Sheets 2, 3) .....	1
FO-19 .....	0
FO-20 (2 Sheets) .....	0
FO-21 (4 Sheets) .....	0
FO-22 .....	0
FO-23 .....	0
FO-24 (3 Sheets) .....	0
FO-25 (2 Sheets) .....	0
FO-26 (2 Sheets) .....	0
FO-27 .....	0

\*Zero in this column indicates an original page.

**Change 2 A/(B blank)**

**ORGANIZATION MAINTENANCE MANUAL: ELECTRONIC CIRCUIT PLUG-IN  
UNIT TEST SET TS-3317**

**GUIDED MISSILE AIR DEFENSE SYSTEM AN/TSQ-73**

**REPORTING ERRORS AND RECOMMENDING IMPROVEMENTS**

You can help improve this publication. If you find any mistakes, or if you know of a way to improve the procedures, please let us know. Mail your Letter, DA Form 2028 (Recommended Changes to Publications and Blank Forms), or DA Form 2028-2 located in back of this manual direct to: Commander, U.S. Army Missile Command, ATTN: DRSMI-SNPM, Redstone Arsenal, AL 35898. A reply will be furnished to you.

**TABLE OF CONTENTS**

Chapter	Page
LIST OF ILLUSTRATIONS .....	iii
LIST OF TABLES .....	v
<b>7</b> <b>MODULE TEST SET EXPANDED TROUBLE-SHOOTING .....</b>	<b>7-1</b>
Section I. INTRODUCTION.....	7-1
7-1.    Scope .....	7-1
7-2.    Expanded Troubleshooting Concept .....	7-1
7-3.    Troubleshooting Aids .....	7-1
7-4.    Physical Description .....	7-1
7-5.    Circuit Card Location Index Tables and Key Signal Lookup Tables .....	7-4
Section II. OVERALL THEORY OF OPERATION .....	7-140
7-6.    Overall Functional Description .....	7-140
Section III. DETAILED DESCRIPTION .....	7-142
7-7.    General .....	7-142
7-8.    State Logic .....	7-142
7-9.    Special Card Test Logic.....	7-155
7-10.   Reset Logic .....	7-159
7-11.   Clock and Timing .....	7-163
7-12.   Test Probe Assembly .....	7-167
7-13.   Card ID Decoder Logic Detailed Description .....	7-167
7-14.   Card ID Random-To-Binary Logic .....	7-173
7-15.   Memory Y-Address .....	7-178

TABLE OF CONTENTS - Continued

Chapter		Page
	7-16. Circuit Test Complete Detector .....	7-178
	7-17. Test Pattern Memory .....	7-178
	7-18. Test Pattern Buffer Logic .....	7-186
	7-19. Circuit Mask Memory Control .....	7-186
	7-20. IC Enable Control Detailed Description .....	7-186
	7-21. Mask Memory Control .....	7-197
	7-22. Control Word Memory .....	7-198
	7-23. I/O Mask Memory Detailed Description .....	7-198
	7-24. Card ID Decode for Clock Insertion .....	7-198
	7-25. Test Clock Control Logic .....	7-213
	7-26. Probe Control Logic .....	7-219
	7-27. Data Compare Logic .....	7-219
	7-28. Error Detection .....	7-220
	7-29. Lamp Driver Logic .....	7-226
	7-30. Lamp Test Logic .....	7-226
	7-31. MTS Interface .....	7-234
	7-32. Self-Test Logic .....	7-234
Section IV.	POWER DISTRIBUTION .....	7-243
7-33.	Power Distribution .....	7-243



## LIST OF ILLUSTRATIONS

Figure	Title	Page
7-1.	Module Test Set Major Assemblies .....	7-2
7-2.	Module Test Set Accessories and Adapters .....	7-3
7-3.	Front Panel Assembly .....	7-8
7-4.	Module Test Set Digital and Analog Card Racks .....	7-9
7-5.	MTS Circuit Card Location .....	7-10
7-6.	Module Test Set Cabling Diagram .....	7-15
7-7.	Module Test Set Block Diagram .....	7-141
7-8.	MTS Functional Block Diagram .....	7-143
7-9.	State Logic Block Diagram .....	7-145
7-10.	State Input Logic Timing Diagram .....	7-149
7-11.	Continuity Test Timer Timing Diagram .....	7-151
7-12.	IOC Error Logic Timing Diagram .....	7-153
7-13.	Special Card Test Logic Block Diagram .....	7-157
7-14.	Reset Logic Block Diagram .....	7-161
7-15.	Clock and Timing Functional Block Diagram .....	7-165
7-16.	Timing Generator Timing Diagram .....	7-168
7-17.	Test Probe Functional Block Diagram .....	7-169
7-18.	Card ID Decoder Block Diagram .....	7-171
7-19.	Card ID Random-to-Binary Block Diagram .....	7-175
7-20.	Self-Test Card ID Timing Diagram .....	7-177
7-21.	Memory Y-Address Block Diagram .....	7-179
7-22.	Memory Y-Address Counter Control Timing Diagram .....	7-181
7-23.	Circuit Test Complete Detector Block Diagram .....	7-183
7-24.	Circuit Test Complete Detector Timing Diagram .....	7-184
7-25.	Test Pattern Memory Block Diagram .....	7-185
7-26.	Test Pattern Buffer Block Diagram .....	7-187
7-27.	Circuit Mask Memory Block Diagram.....	7-189
7-28.	IC Circuit Counter Timing Diagram .....	7-191
7-29.	IC Enable Control Block Diagram .....	7-193
7-30.	IC Counter Control Timing Diagram .....	7-195
7-31.	IC Counter Timing Diagram .....	7-199
7-32.	Circuits Counter Timing Diagram .....	7-201
7-33.	Mask Memory Control Block Diagram .....	7-203
7-34.	Control Word Memory Block Diagram .....	7-205
7-35.	Control Word A and B ROM Storage Simplified Block Diagram .....	7-207
7-36.	I/O Mask Memory Block Diagram .....	7-209
7-37.	Card ID Decode for Clock Insertion Block Diagram .....	7-211
7-38.	Test Clock Control Block Diagram .....	7-215
7-39.	Test Clock Control Timing Diagram .....	7-217
7-40.	Probe Control Logic Block Diagram .....	7-221
7-41.	Data Compare Logic Block Diagram .....	7-223
7-42.	Error Detection Block Diagram .....	7-225
7-43.	Lamp Driver Logic Block Diagram .....	7-229
7-44.	Relationship of Signal Mnemonics to Front Panel Error Lamps .....	7-231
7-45.	Lamp Test Logic Block Diagram.....	7-232
7-46.	Typical Lamp Test Circuit Simplified Schematic .....	7-233
7-47.	Self-Test Logic Functional Block Diagram .....	7-237

## LIST OF ILLUSTRATIONS - Continued

Figure	Title	Page
748.	Self-Test Control Logic and 72 Clock-Pulse Generator Timing Diagram .....	7-239
749.	Self-Test Pattern Check Sum Timing Diagram and Truth Table .....	7-241
7-50.	Self-Test Error Example .....	7-242
7-51.	Power Distribution Block Diagram .....	7-243
FO-1.	Card ID Decoder Logic Diagram .....	
FO-2.	Card ID Random to Binary Logic Diagram .....	
FO-3.	Circuit Mask Memory Control Log .....	
	Diagram .....	
FO-4.	Memory Y Address Logic Diagram .....	
FO-5.	IC Enable Control Logic Diagram .....	
FO-6.	Mask Memory Control Logic Diagram .....	
FO-7.	I/O Mask Memory Logic Diagram .....	
FO-8.	Circuit Test Complete Detector Logic Diagram .....	
FO-9.	Clock and Timing Logic Diagram .....	
FO-10.	Test Pattern Buffer Logic Diagram .....	
FO-11.	Test Pattern Memory Logic Diagram .....	
FO-12.	Control Word Memory Logic Diagram .....	
FO-13.	Test Clock Control Logic Diagram .....	
FO-14.	Self Test Logic Diagram .....	
FO-15.	Probe Control Logic Diagram .....	
FO-16.	Card ID Decode for Clock Insertion Logic Diagram .....	
FO-17.	Error Detection Logic Diagram .....	
FO-18.	State Logic Diagram .....	
FO-19.	Special Card Test Logic Diagram .....	
FO-20.	Lamp Driver Logic Diagram .....	
FO-21.	Data Compare Logic Diagram .....	
FO-22.	Reset Logic Diagram .....	
FO-23.	Lamp Test Logic Diagram .....	
FO-24.	Front Panel Schematic Diagram .....	
FO-25.	Power Distribution Diagram .....	
FO-26.	Probe Assembly Schematic Diagram .....	
FO-27.	MTS Test Interface Connector Diagram .....	

## LIST OF TABLES

Table	Title	Page
7-1.	AN/TSQ-73 Major Equipment Cross-Reference .....	74
7-2.	Module Test Set, Major Assembly Cross-Reference .....	7-7
7-3.	Module Test Set, Circuit Card Location .....	7-11
7-4.	Left Hand Digital Card Rack Card Location Index .....	7-17
7-5.	Right Hand Digital Card Rack Card Location Index .....	7-19
7-6.	Analog Card Rack Card Location Index .....	7-21
7-7.	Left Hand Digital Card Cage Key Signal Lookup .....	7-22
7-8.	Right Hand Digital Card Cage Key Signal Lookup .....	7-51
7-9.	Analog Assembly Key Signal Lookup .....	7-86
7-10.	MTS Interconnecting Key Signal Lookup .....	7-113
7-11.	Test Probe Assembly Key Signal Lookup .....	7-133
7-12.	Display Reset Latch Truth Table .....	7-163
7-13.	Repeat Cycle Latch and FF Truth Table .....	7-163
7-14.	Clock Select Truth Table .....	7-167
7-15.	Card ID Decoder Truth Table .....	7-174
7-16.	Strobe Generator Truth Table .....	7-208
7-17.	Special Card Test Control Logic, Truth Table .....	7-213
7-18.	Control Logic for Single Card Test +5v Supply, Truth Table .....	7-214
7-19.	Error Detection Truth Table .....	7-227
7-20.	Lamp Test Signals for Related Indicators .....	7-235

v/(vi blank)

INPUT		OUTPUT	
FO-SH		FO-SH	
HBSBAY	18-1	HBB77P	18-2
HBS10P	18-1	HBB15A	18-1, 18-3
H2180	19	HBB20	2
H21C0	19	HBB220	2
HBS12P	18-1	HBB230	2
HBS10	18-1	HBB240	2
HBS11A	18-2	HBB250	2
HBS14	18-2	HBB250	2
H43A0	26	HBB255	19
H40B0	26	HBS10V	18-3
H40	26	HBS24	18-3
H20A0	25		

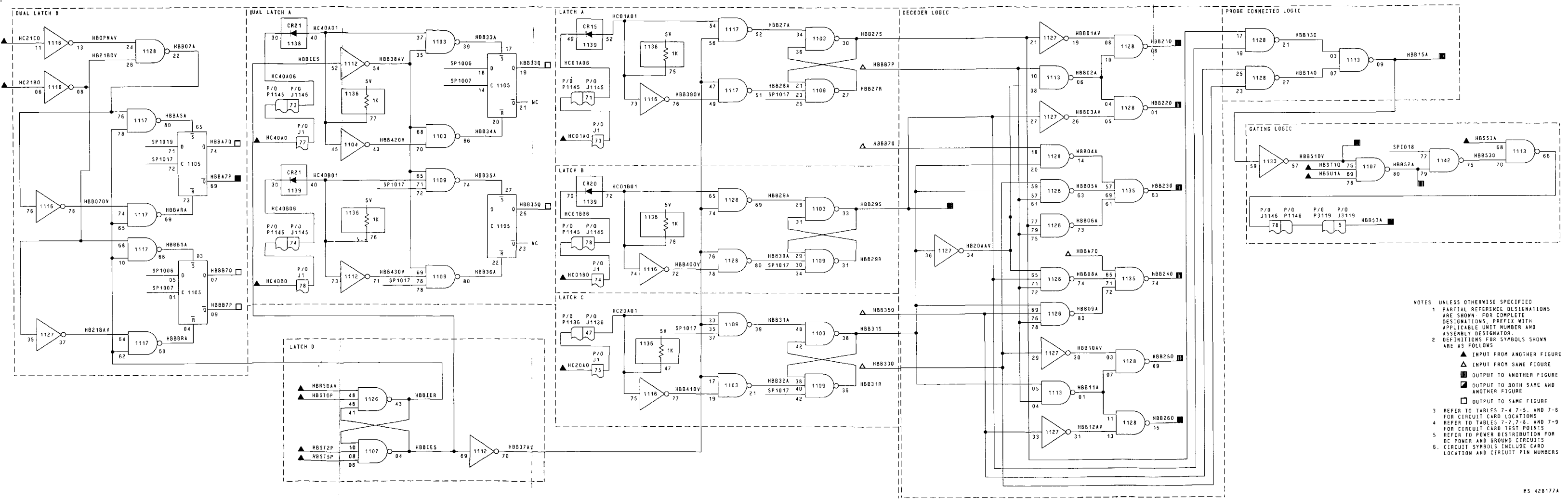

- NOTES UNLESS OTHERWISE SPECIFIED
- PARTIAL REFERENCE DESIGNATIONS ARE SHOWN FOR COMPLETE DESIGNATIONS. PREFIX WITH APPLICABLE UNIT NUMBER AND ASSEMBLY DESIGNATOR.
  - DEFINITIONS FOR SYMBOLS SHOWN ARE AS FOLLOWS:
    - ▲ INPUT FROM ANOTHER FIGURE
    - ▲ INPUT FROM SAME FIGURE
    - OUTPUT TO ANOTHER FIGURE
    - OUTPUT TO BOTH SAME AND ANOTHER FIGURE
    - OUTPUT TO SAME FIGURE
  - REFER TO TABLES 7-4, 7-5, AND 7-6 FOR CIRCUIT CARD LOCATIONS.
  - REFER TO TABLES 7-7, 7-8, AND 7-9 FOR CIRCUIT CARD TEST POINTS.
  - REFER TO POWER DISTRIBUTION FOR DC POWER AND GROUND CIRCUITS.
  - CIRCUIT SYMBOLS INCLUDE CARD LOCATION AND CIRCUIT PIN NUMBERS.

FO-1. Card ID Decoder Logic Diagram

Change 1

INPUT		FO-SH	
HAFBQ	5		
HBB210	1		
HBB220	1		
HBB230	1		
HBB240	1		
HBB250	1		
HBB260	1		
HBFBCAV	22		
HBFB1P	22		
HBT1A0V	9-1		
HK10	18-3		
HJAGAV	17		
HBST7P	18-1		

OUTPUT		FO-SH	
HBCASA	22		
HBCID8V1	22		
HBCIOB1	3, 4, 7-1		
HBCI1B1	8, 14-2, 16		
HBCI2B1	3, 4, 7-1		
HBCI3B1	8, 14-2, 16		
HBCI4B1	3, 4, 7-1		
HBCI5B1	8, 14-2, 16		
HBCR1P	17		
HBCR2P	18-1		
HBCR2Q	14-2		
HBCST06	23, 24		
HBCSTAV	23, 22		
HBC TSA	18-1, 24		

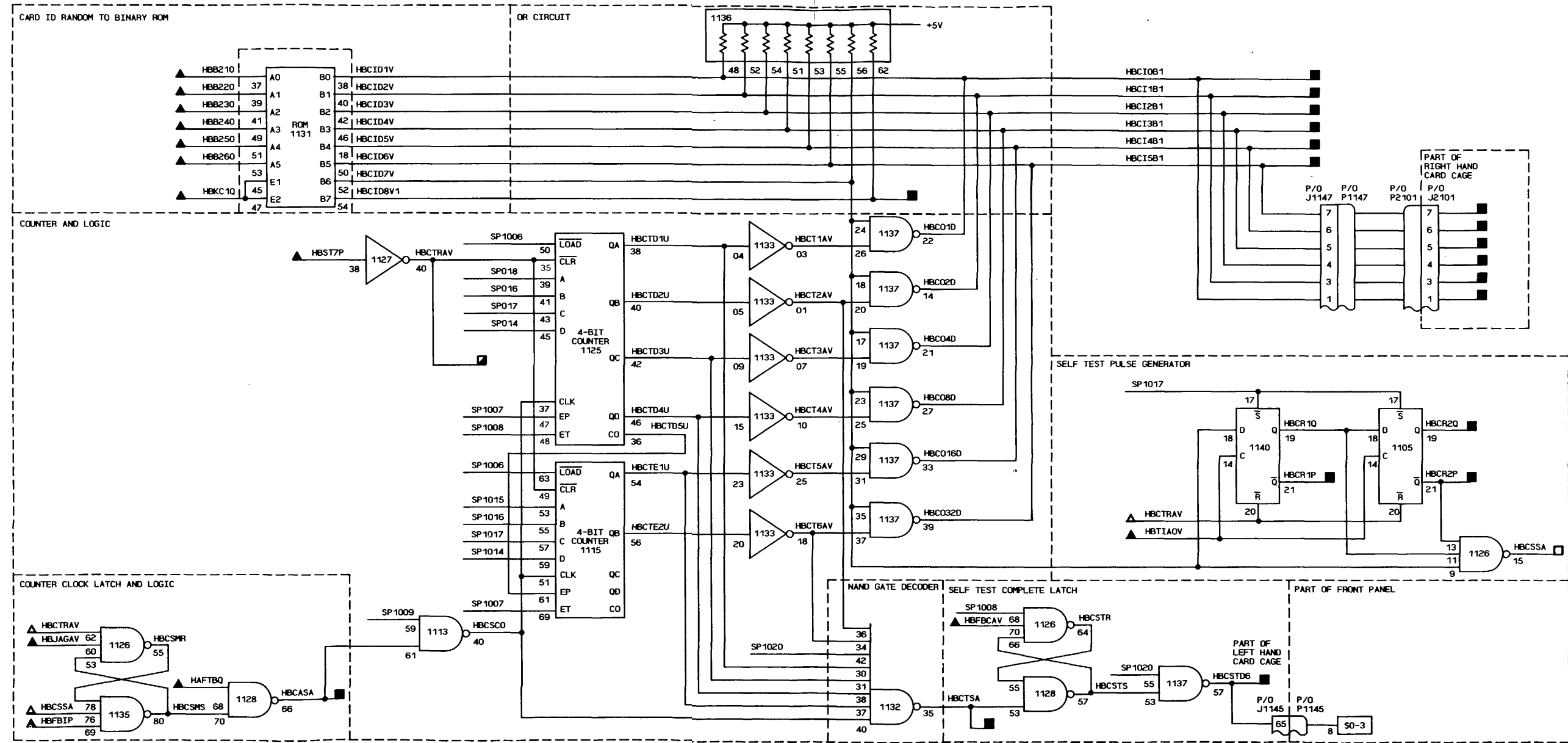

- NOTES: UNLESS OTHERWISE SPECIFIED
- PARTIAL REFERENCE DESIGNATIONS ARE SHOWN. FOR COMPLETE DESIGNATIONS, PREFIX WITH APPLICABLE UNIT NUMBER AND ASSEMBLY DESIGNATOR.
  - DEFINITIONS FOR SYMBOLS SHOWN ARE AS FOLLOWS:
    - ▲ INPUT FROM ANOTHER FIGURE
    - ▲ INPUT FROM SAME FIGURE
    - OUTPUT TO ANOTHER FIGURE
    - OUTPUT TO BOTH SAME AND ANOTHER FIGURE
    - OUTPUT TO SAME FIGURE
  - REFER TO TABLES 7-4, 7-5, AND 7-6 FOR CIRCUIT CARD LOCATIONS.
  - REFER TO TABLES 7-7, 7-8, AND 7-9 FOR CIRCUIT CARD TEST POINTS.
  - REFER TO POWER DISTRIBUTION FOR DC POWER AND GROUND CIRCUITS.
  - CIRCUIT SYMBOLS INCLUDE CARD LOCATION AND CIRCUIT PIN NUMBERS.

MS 428178

FO-2. Card ID Random to Binary Logic Diagram

FO-2. Card ID Random to Binary Logic Diagram

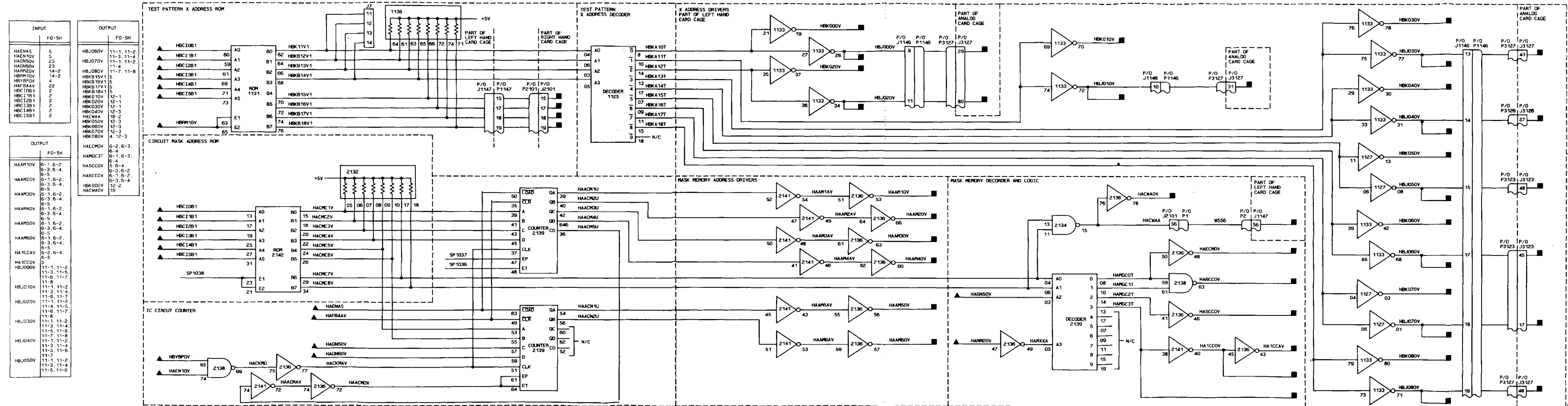

FO-3. Circuit Mask Memory Control Logic Diagram

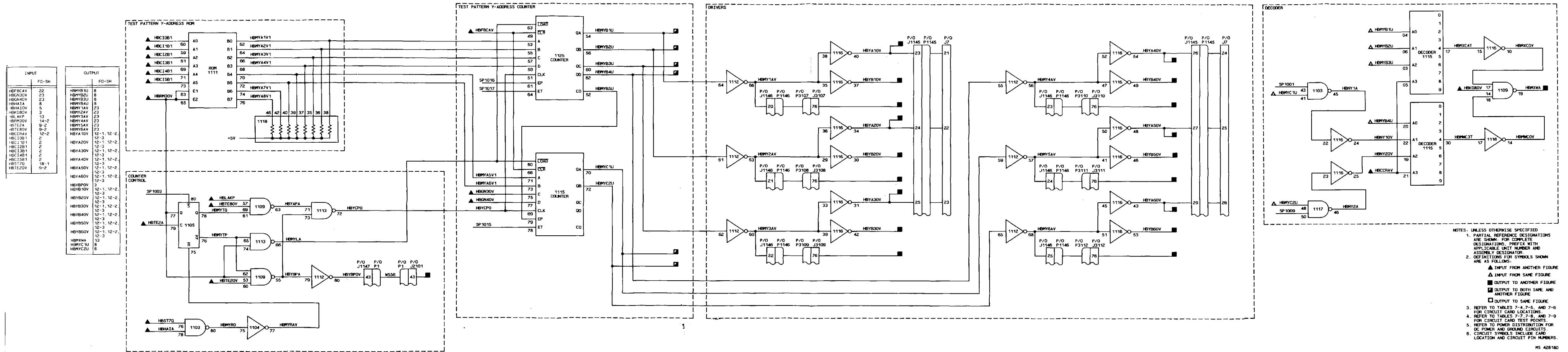

FO-4. Memory Y Address Logic Diagram

INPUT		FO-SH	
HA1CCOV	3	HAENAS	3
HA1B10V1	3	HAEN1A	6-1
HA1B16V1	3	HAEN1A	6-1,6-2
HA1B17V1	3	HAEN10V	3,6-1
HA1B18V1	3	HAEN20V	6-1,6-2
HA1B19V1	3	HAEN2A	6-2
HA1C4OV	9-1	HAEN2OV	6-2,6-3
HA1R2OV	14-2	HAEN3A	6-3
HA1S3OV	3	HAEN3OV	6-3,6-4
HA1S4OV	3	HAEN4A	6-4
HA1S5OV	3	HAEN4OV	6-4
HA1S6OV	3	HAEN5A	6-5
HA1S7OV	3	HAEN5OV	6-5
HA1S8OV	3	HAEN6A	6-6
HA1S9OV	3	HAEN6OV	6-6
HA1T1OV	14-1	HAEN7A	6-7
HA1T2OV	14-2	HAEN7OV	6-7
HA1T3OV	18-1	HAEN8A	6-8
HA1T4OV	18-2	HAEN8OV	6-8

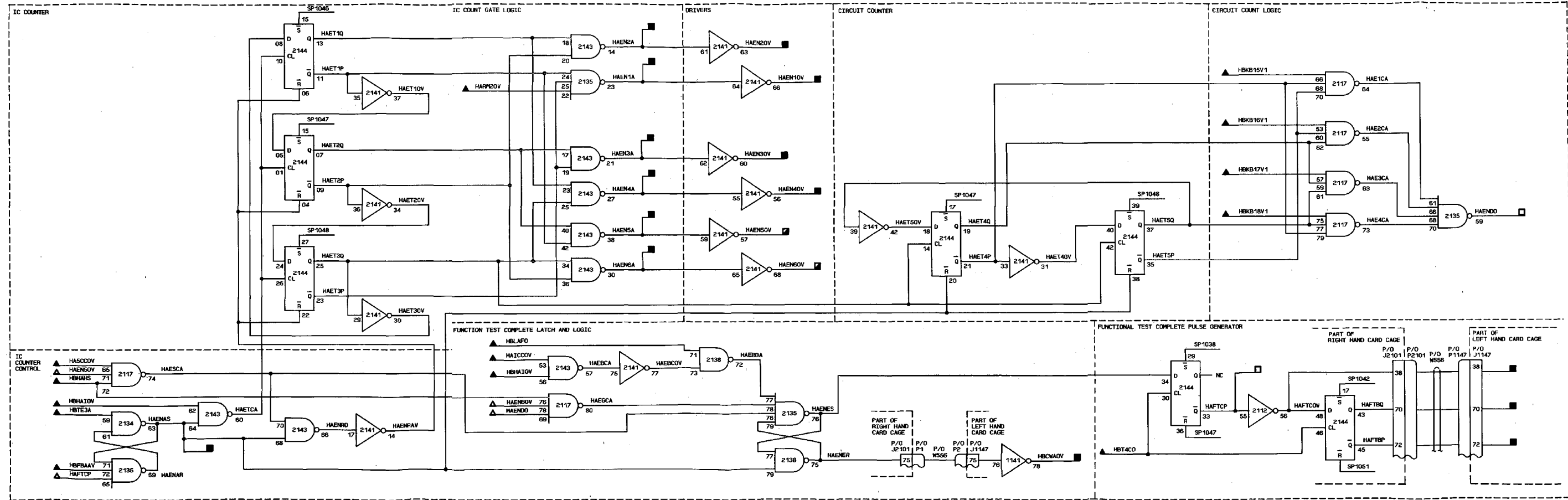

- NOTES: UNLESS OTHERWISE SPECIFIED
- PARTIAL REFERENCE DESIGNATIONS ARE SHOWN FOR COMPLETE DESIGNATIONS. PREFIX WITH APPLICABLE UNIT NUMBER AND ASSEMBLY DESIGNATOR.
  - DEFINITIONS FOR SYMBOLS SHOWN ARE AS FOLLOWS:
    - ▲ INPUT FROM ANOTHER FIGURE
    - ▲ INPUT FROM SAME FIGURE
    - OUTPUT TO ANOTHER FIGURE
    - OUTPUT TO BOTH SAME AND ANOTHER FIGURE
    - OUTPUT TO SAME FIGURE
  - REFER TO TABLES 7-4, 7-5, AND 7-6 FOR CIRCUIT CARD LOCATIONS.
  - REFER TO TABLES 7-7, 7-8, AND 7-9 FOR CIRCUIT CARD TEST POINTS.
  - REFER TO POWER DISTRIBUTION FOR DC POWER AND GROUND CIRCUITS.
  - CIRCUIT SYMBOLS INCLUDE CARD LOCATION AND CIRCUIT PIN NUMBERS.

FO-5. IC Enable Control Logic Diagram



INPUT		OUTPUT		OUTPUT	
	FO-SH		FO-SH		FO-SH
HAGC31	3	HAG21A	21-1	HAG150V	15-1, 15-7
HAGC32	3	HAG21B	21-1	HAG21C	21-2
HAGC33	3	HAG21C	21-1	HAG21D	15-1, 21-2
HAGC34	3	HAG21D	21-1	HAG21E	15-1, 15-7
HAGC35	3	HAG21E	21-1	HAG21F	15-1, 21-2
HAGC36	3	HAG21F	21-1	HAG21G	15-2, 21-2
HAGC37	3	HAG21G	21-1	HAG21H	15-2, 21-2
HAGC38	3	HAG21H	21-1	HAG21I	15-2, 21-2
HAGC39	3	HAG21I	21-1	HAG21J	15-2, 21-2
HAGC40	3	HAG21J	21-1	HAG21K	15-2, 21-2
HAGC41	3	HAG21K	21-1	HAG21L	15-2, 21-2
HAGC42	3	HAG21L	21-1	HAG21M	15-2, 21-2
HAGC43	3	HAG21M	21-1	HAG21N	15-2, 21-2
HAGC44	3	HAG21N	21-1	HAG21O	15-2, 21-2
HAGC45	3	HAG21O	21-1	HAG21P	15-2, 21-2
HAGC46	3	HAG21P	21-1	HAG21Q	15-2, 21-2
HAGC47	3	HAG21Q	21-1	HAG21R	15-2, 21-2
HAGC48	3	HAG21R	21-1	HAG21S	15-2, 21-2
HAGC49	3	HAG21S	21-1	HAG21T	15-2, 21-2
HAGC50	3	HAG21T	21-1	HAG21U	15-2, 21-2
HAGC51	3	HAG21U	21-1	HAG21V	15-2, 21-2
HAGC52	3	HAG21V	21-1	HAG21W	15-2, 21-2
HAGC53	3	HAG21W	21-1	HAG21X	15-2, 21-2
HAGC54	3	HAG21X	21-1	HAG21Y	15-2, 21-2
HAGC55	3	HAG21Y	21-1	HAG21Z	15-2, 21-2
HAGC56	3	HAG21Z	21-1		
HAGC57	3				
HAGC58	3				
HAGC59	3				
HAGC60	3				
HAGC61	3				
HAGC62	3				
HAGC63	3				
HAGC64	3				
HAGC65	3				
HAGC66	3				
HAGC67	3				
HAGC68	3				
HAGC69	3				
HAGC70	3				
HAGC71	3				
HAGC72	3				
HAGC73	3				
HAGC74	3				
HAGC75	3				
HAGC76	3				
HAGC77	3				
HAGC78	3				
HAGC79	3				
HAGC80	3				
HAGC81	3				
HAGC82	3				
HAGC83	3				
HAGC84	3				
HAGC85	3				
HAGC86	3				
HAGC87	3				
HAGC88	3				
HAGC89	3				
HAGC90	3				
HAGC91	3				
HAGC92	3				
HAGC93	3				
HAGC94	3				
HAGC95	3				
HAGC96	3				
HAGC97	3				
HAGC98	3				
HAGC99	3				
HAGC100	3				

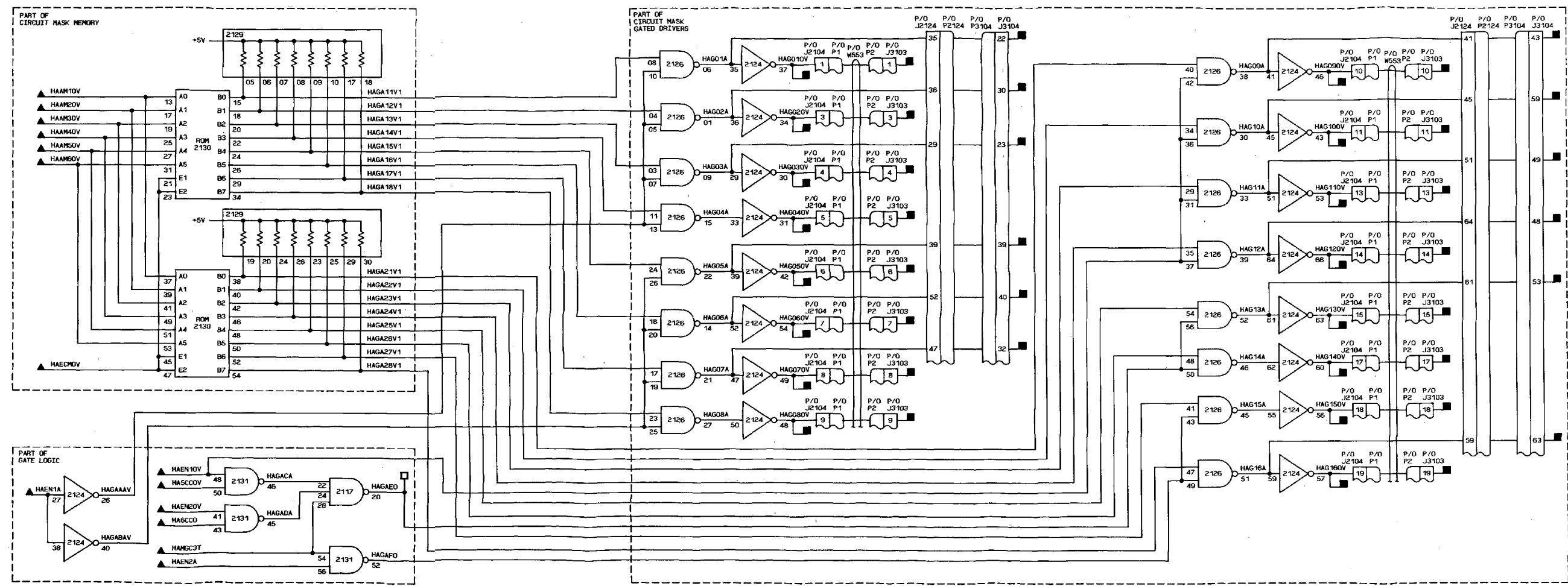

NOTES: UNLESS OTHERWISE SPECIFIED  
 1. PARTIAL REFERENCE DESIGNATIONS ARE SHOWN; FOR COMPLETE DESIGNATIONS, PREFIX WITH APPLICABLE UNIT NUMBER AND ASSEMBLY DESIGNATOR.  
 2. DEFINITIONS FOR SYMBOLS SHOWN ARE AS FOLLOWS:  
 ▲ INPUT FROM ANOTHER FIGURE  
 △ INPUT FROM SAME FIGURE  
 □ OUTPUT TO ANOTHER FIGURE  
 ■ OUTPUT TO BOTH SAME AND ANOTHER FIGURE  
 □ OUTPUT TO SAME FIGURE  
 3. REFER TO TABLES 7-4, 7-5, AND 7-6 FOR CIRCUIT CARD LOCATIONS.  
 4. REFER TO TABLES 7-7, 7-8, AND 7-9 FOR CIRCUIT CARD TEST POINTS.  
 5. REFER TO POWER DISTRIBUTION FOR DC POWER AND GROUND CIRCUITS.  
 6. CIRCUIT SYMBOLS INCLUDE CARD LOCATION AND CIRCUIT PIN NUMBERS.

FO-6. Mask Memory Control Logic Diagram (Sheet 1 of 5)

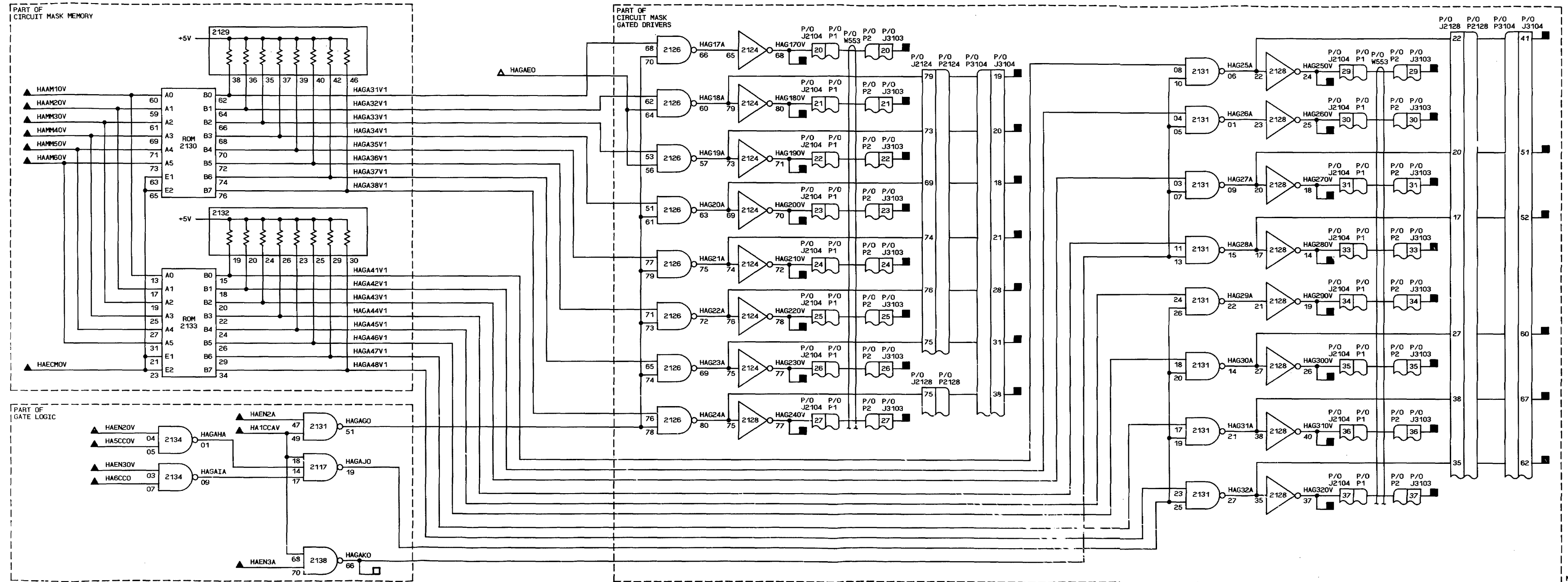

MS 428183

FO-6. Mask Memory Control Logic Diagram (Sheet 2 of 5)

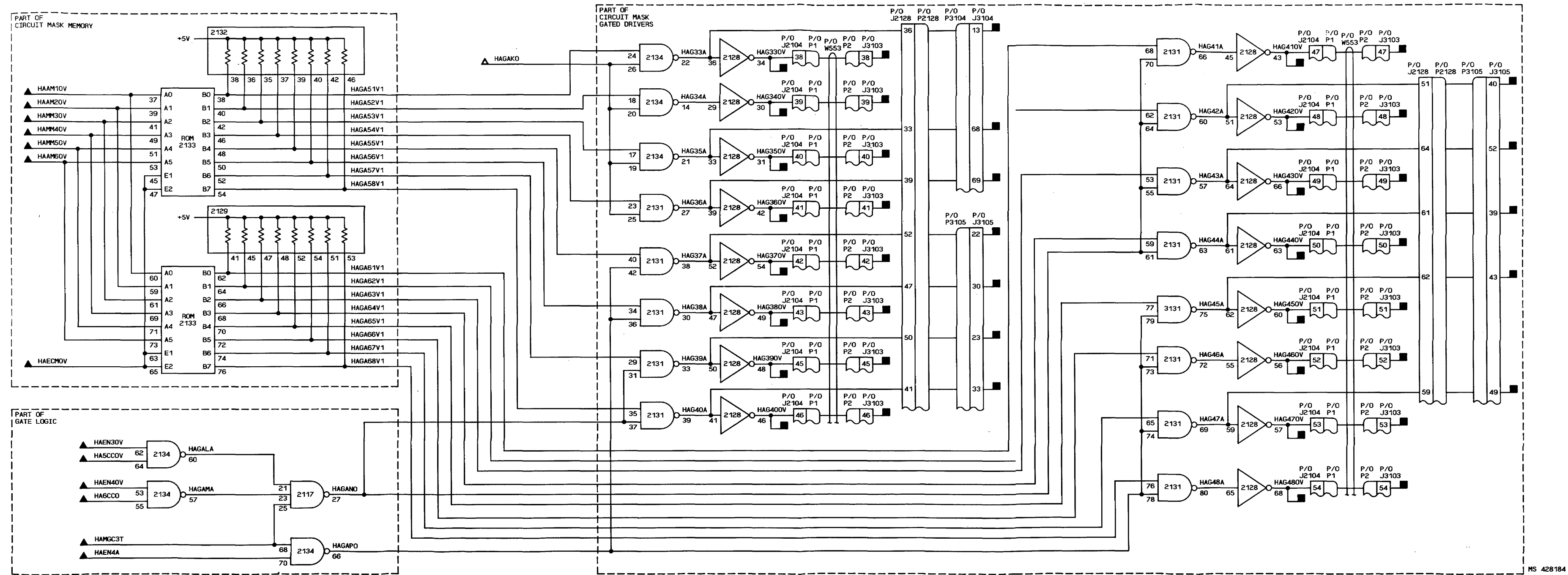

MS 428184

FO-6. Mask Memory Control Logic Diagram (Sheet 3 of 5)

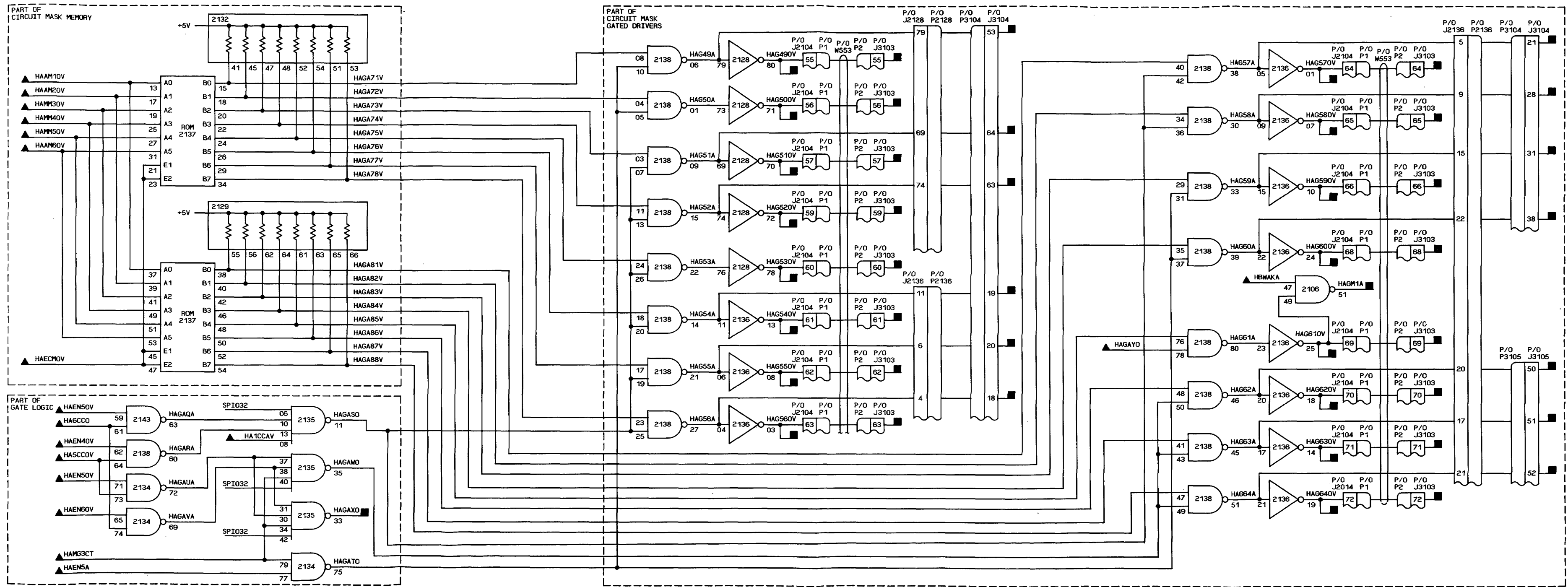

MS 428185

FO-6. Mask Memory Control Logic Diagram (Sheet 4 of 5)

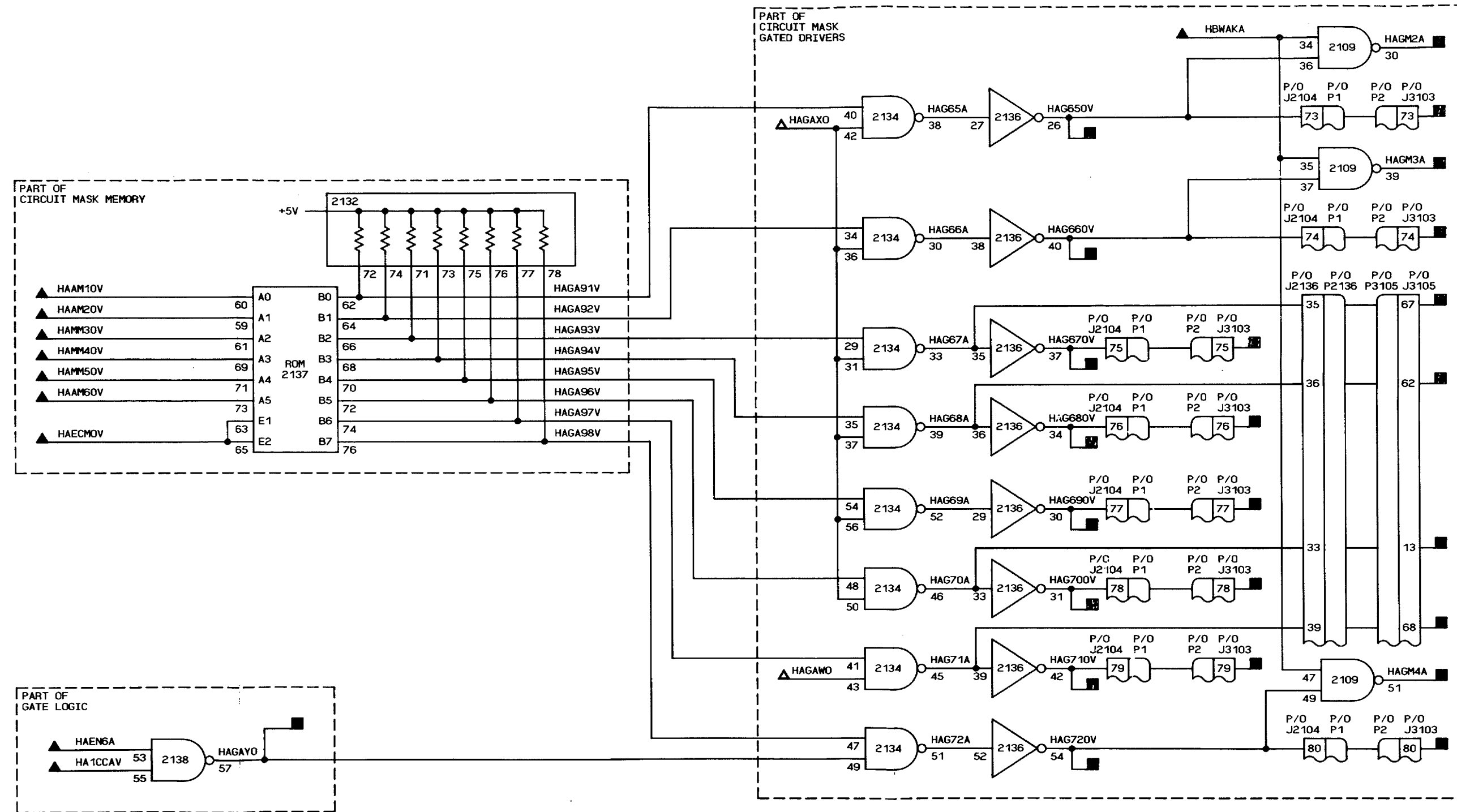

MS 428186

FO-6. Mask Memory Control Logic Diagram (Sheet 5 of 5)

INPUT	
	FO-SH
HARM4CV	14-2
HARM50V	14-2
HBC10B1	2
HBC11B1	2
HBC12B1	2
HBC13B1	2
HBC14B1	2
HBC15B1	2

OUTPUT	
	FO-SH
HAHO11V1	15-1, 21-1
HAHO12V1	15-1, 21-1
HAHO13V1	15-1, 21-1
HAHO14V1	15-1, 15-7
HAHO15V1	15-1, 21-1
HAHO16V1	15-1, 21-1
HAHO17V1	15-2, 21-2
HAHO18V1	15-2, 15-7
HAHO21V1	15-5, 21-3
HAHO22V1	15-5, 15-7
HAHO23V1	15-5, 21-3
HAHO24V1	15-5, 21-3
HAHO25V1	15-2, 21-2
HAHO26V1	15-1, 15-7
HAHO27V1	15-1, 15-7
HAHO28V1	15-1, 21-2
HAHO31V1	15-1, 15-7
HAHO32V1	15-1, 21-2
HAHO33V1	15-2, 21-2
HAHO34V1	15-2, 21-2
HAHO35V1	15-2, 21-2
HAHO36V1	15-2, 21-2
HAHO37V1	15-2, 21-2
HAHO38V1	15-2, 21-2
HAHO42V1	15-3, 15-7
HAHO43V1	15-3, 21-2
HAHO44V1	15-3, 21-2
HAHO45V1	15-3, 15-7
HAHO46V1	15-3, 21-2
HAHO47V1	15-4, 21-3
HAHO48V1	15-4, 21-3
HAHO51V1	15-4
HAHO52V1	15-4, 15-7
HAHO53V1	21-3
HAHO54V1	15-4, 21-3
HAHO55V1	15-3, 21-3
HAHO56V1	15-3, 21-3
HAHO57V1	15-3, 21-3
HAHO58V1	15-3, 21-3
HAHO61V1	21-3

OUTPUT	
	FO-SH
HAHO62V1	15-3, 21-3
HAHO63V1	15-4, 21-3
HAHO64V1	15-4, 21-3
HAHO65V1	15-4, 21-3
HAHO66V1	15-4, 15-7
HAHO67V1	15-4, 21-3
HAHO68V1	15-4, 15-7
HAHO71V1	15-5, 21-3
HAHO72V1	15-5, 15-7
HAHO73V1	15-5, 21-3
HAHO74V1	15-5, 21-3
HAHO75V1	15-5, 15-7
HAHO76V1	15-5, 21-3
HAHO77V1	15-6, 21-4
HAHO78V1	15-6, 21-4
HAHO79V1	15-6, 21-4
HAHO82V1	15-6, 21-4
HAHO83V1	15-6, 21-4
HAHO84V1	15-6, 21-4
HAHO85V1	15-6, 21-4
HAHO86V1	15-5, 21-4
HAHO87V1	15-5, 21-4
HAHO88V1	15-5, 21-4
HAHO89V1	15-5, 21-4
HAHO93V1	15-6, 21-4
HAHO94V1	15-6, 21-4
HAHO95V1	15-6, 21-4
HAHO96V1	15-6, 21-4
HAHO97V1	15-6, 21-4
HAHO98V1	15-6, 21-4
HAHO99V1	21-1
HAHA1AV	21-1
HAHA2AV	21-1
HAHA3AV	21-1
HAHA4AV	21-1
HAHA5AV	21-1
HAHA6AV	21-1

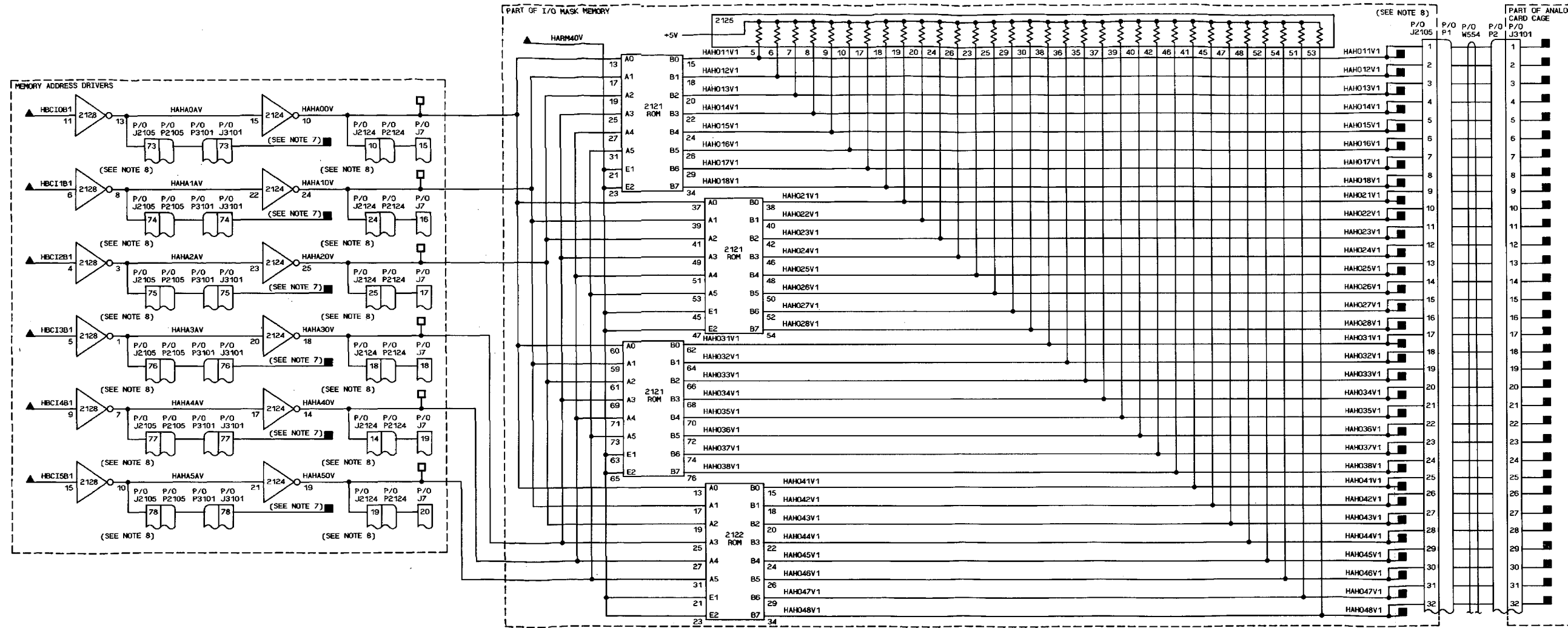

- NOTES: UNLESS OTHERWISE SPECIFIED
- PARTIAL REFERENCE DESIGNATIONS ARE SHOWN. FOR COMPLETE DESIGNATIONS, PREFIX WITH APPLICABLE UNIT NUMBER AND ASSEMBLY DESIGNATOR.
  - DEFINITIONS FOR SYMBOLS SHOWN ARE AS FOLLOWS:
    - ▲ INPUT FROM ANOTHER FIGURE
    - ▲ INPUT FROM SAME FIGURE
    - OUTPUT TO BOTH SAME AND ANOTHER FIGURE
    - OUTPUT TO SAME FIGURE
  - REFER TO TABLES 7-4, 7-5, AND 7-6 FOR CIRCUIT CARD LOCATIONS.
  - REFER TO TABLES 7-7, 7-8, AND 7-9 FOR CIRCUIT CARD TEST POINTS.
  - REFER TO POWER DISTRIBUTION FOR DC POWER AND GROUND CIRCUITS.
  - CIRCUIT SYMBOLS INCLUDE CARD LOCATION AND CIRCUIT PIN NUMBERS.
  - PART OF ANALOG CARD CAGE.
  - PART OF RIGHT HAND CARD CAGE.

FO-7. I/O Mask Memory Logic Diagram (Sheet 1 of 2)

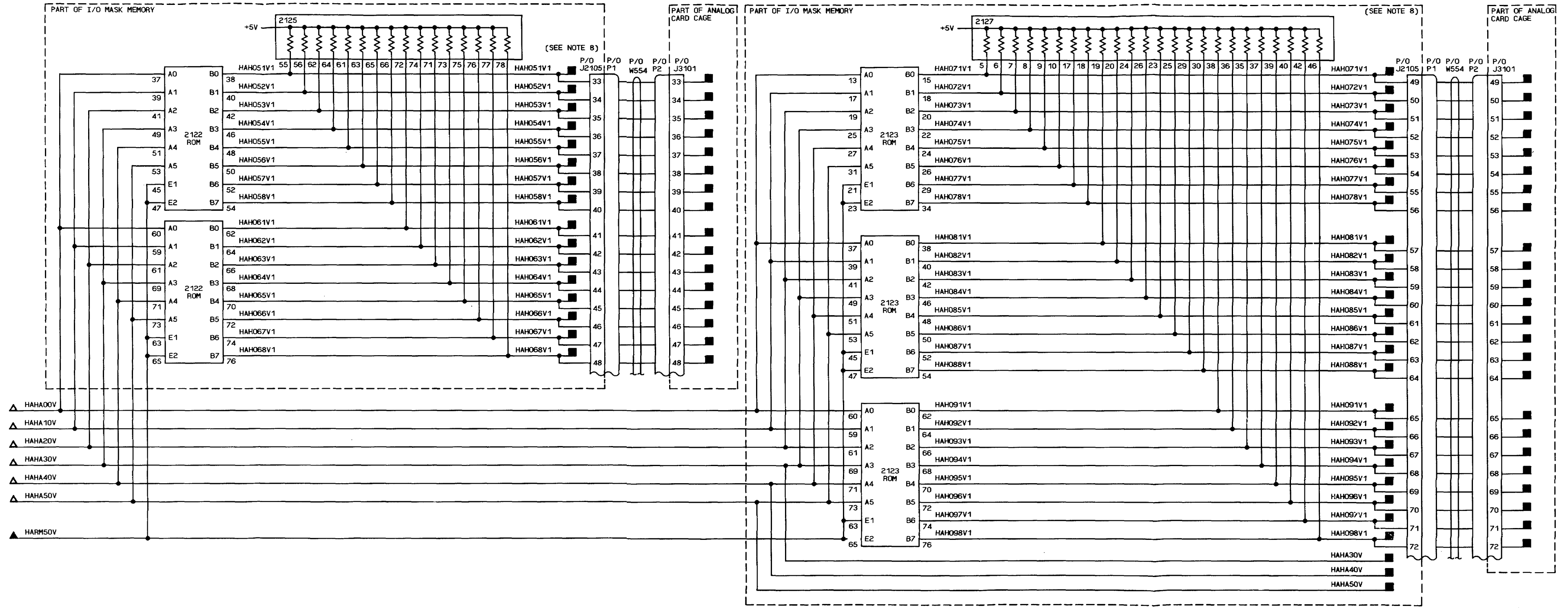

FO-7. I/O Mask Memory Logic Diagram (Sheet 2 of 2)

INPUT	
	FO-SH
HBMXB1U	4
HBMXB2U	4
HBMXB3U	4
HBMXB4U	4
HBRM10V	14-2
HBTE60V	9-2
HBCI0B1	2
HBCI1B1	2
HBCI2B1	2
HBCI3B1	2
HBCI4B1	2
HBCI5B1	2
HBLAF0	13
HBMXC1U	4
HBMXC2U	4
HBTE5A	9-2
HBTE80V	9-2

OUTPUT	
	FO-SH
HBHAI A	4
HBHAI OV	5
HBHAHS	5

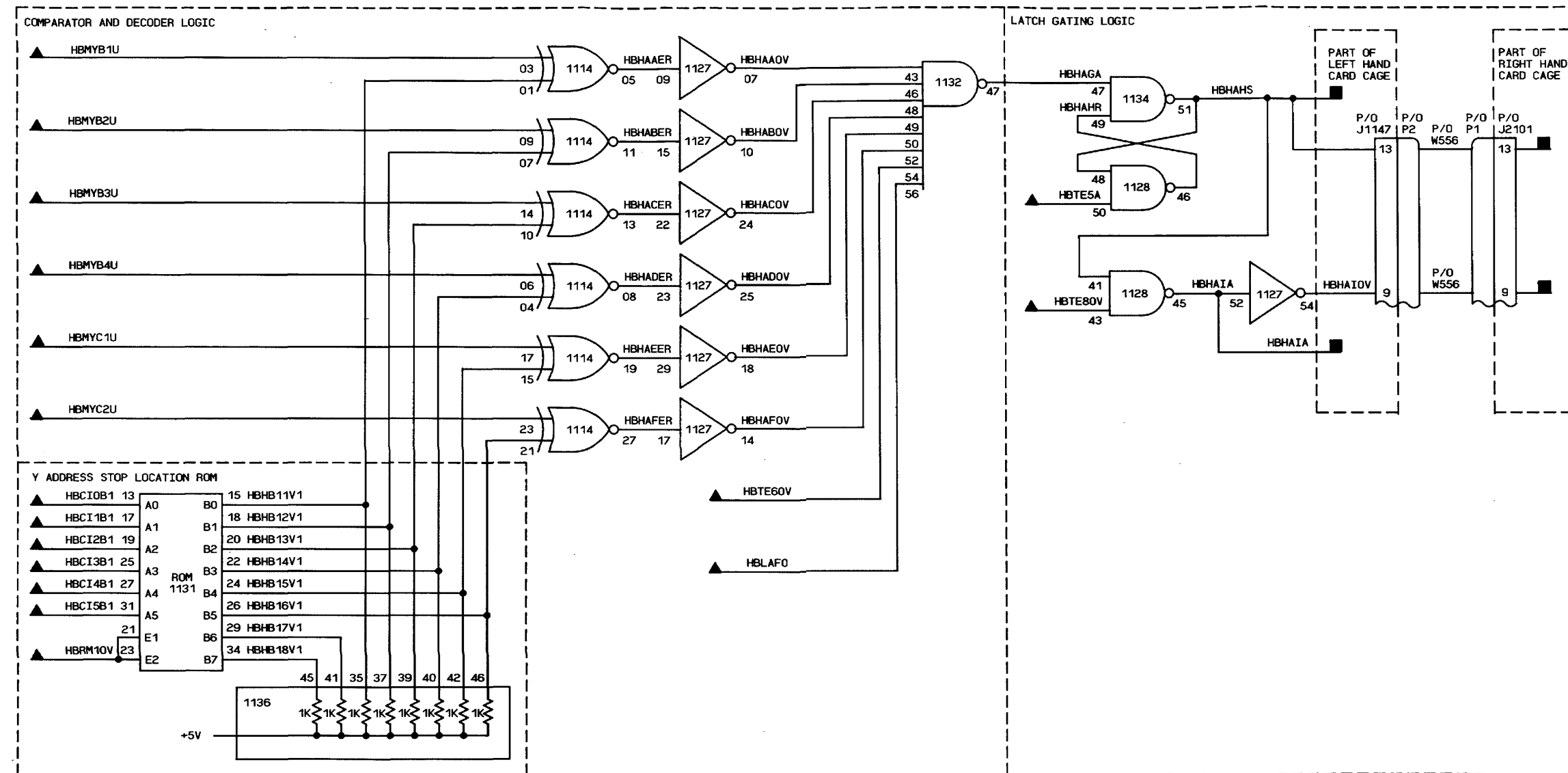

- NOTES: UNLESS OTHERWISE SPECIFIED
- PARTIAL REFERENCE DESIGNATIONS ARE SHOWN: FOR COMPLETE DESIGNATIONS, PREFIX WITH APPLICABLE UNIT NUMBER AND ASSEMBLY DESIGNATOR.
  - DEFINITIONS FOR SYMBOLS SHOWN ARE AS FOLLOWS:
    - ▲ INPUT FROM ANOTHER FIGURE
    - ▲ INPUT FROM SAME FIGURE
    - OUTPUT TO ANOTHER FIGURE
    - OUTPUT TO BOTH SAME AND ANOTHER FIGURE
    - OUTPUT TO SAME FIGURE
  - REFER TO TABLES 7-4, 7-5, AND 7-6 FOR CIRCUIT CARD LOCATIONS.
  - REFER TO TABLES 7-7, 7-8, AND 7-9 FOR CIRCUIT CARD TEST POINTS.
  - REFER TO POWER DISTRIBUTION FOR DC POWER AND GROUND CIRCUITS.
  - CIRCUIT SYMBOLS INCLUDE CARD LOCATION AND CIRCUIT PIN NUMBERS.

FO-8. Circuit Test Complete Detector Logic Diagram





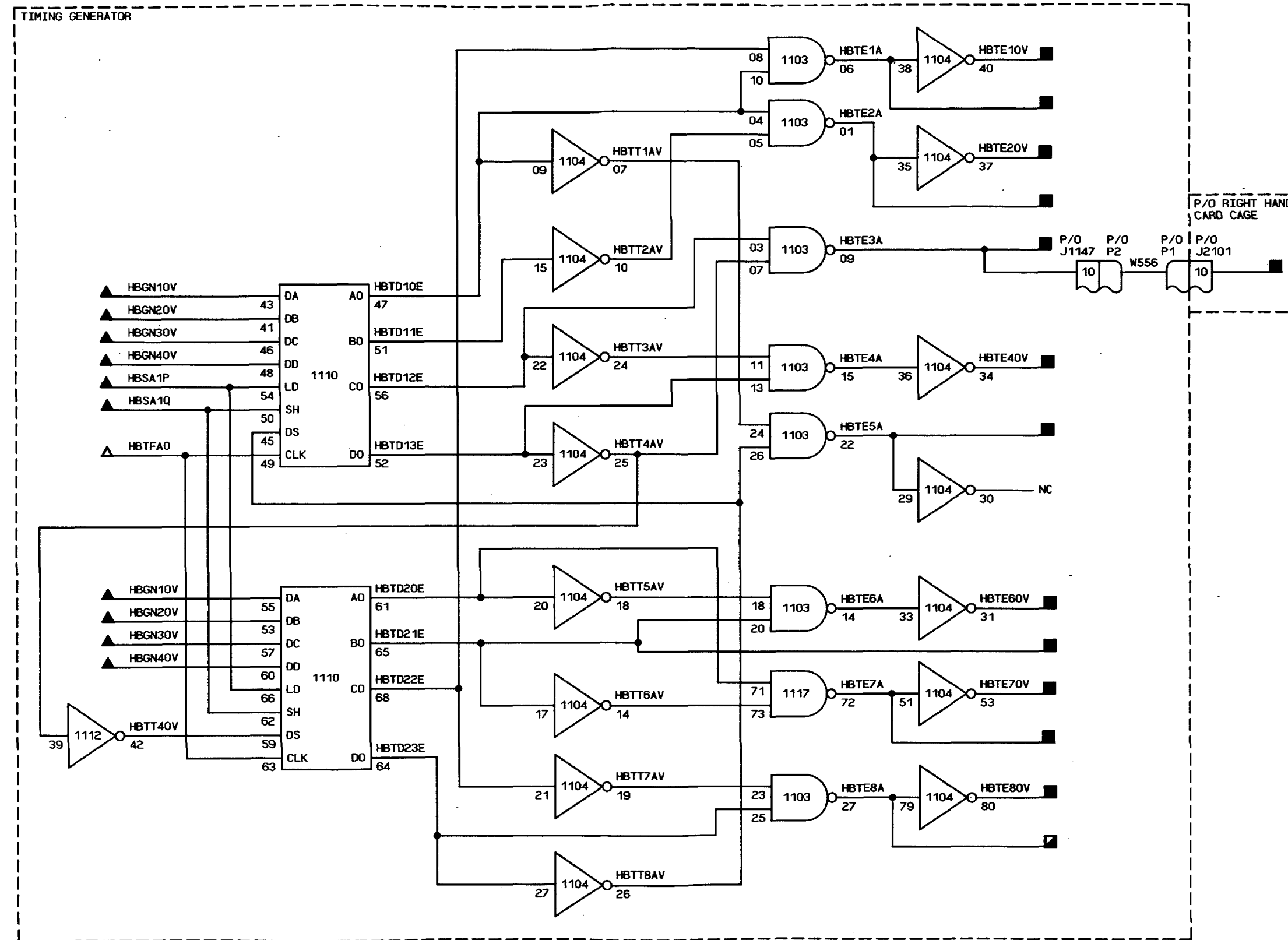

MS 428191

FO-9. Clock and Timing Logic Diagram (Sheet 2 of 2)

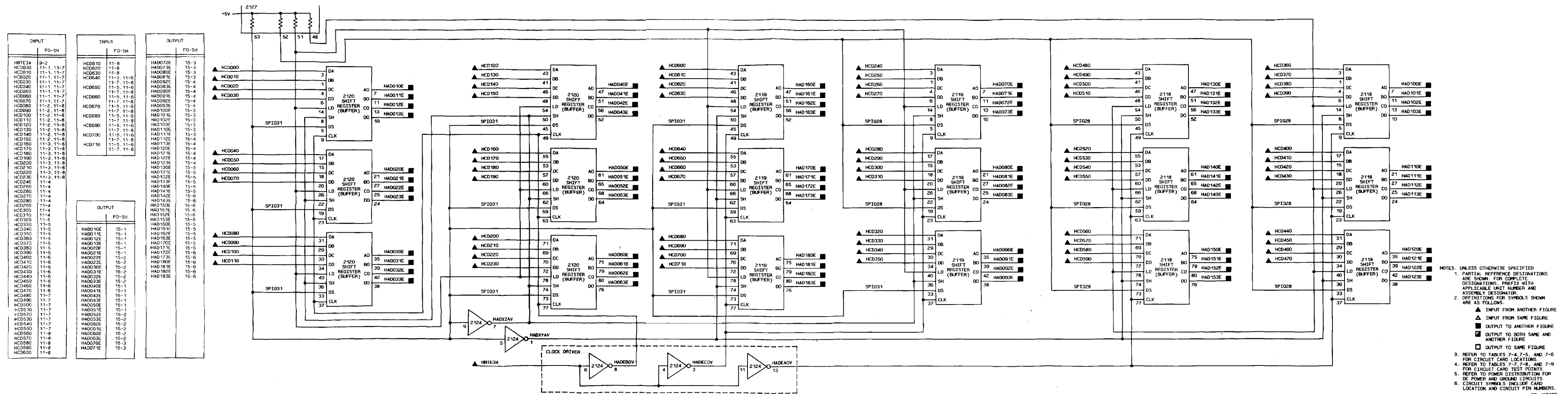

FO-10. Test Pattern Buffer Logic Diagram

INPUT	
	FO-SH
HBJ000V	3
HBJ010V	3
HBJ020V	3
HBJ030V	3
HBJ040V	3
HBJ050V	3
HBJ060V	3
HBJ070V	3
HBJ080V	3
HCAD00	23
HCAD10	23
HCAD20	23
HCAD30	23
HCAD40	23
HCAD50	23
HCID00	21
HCID10	21
HCID20	21
HCID30	21
HCID40	21
HCID50	21

OUTPUT	
	FO-SH
HCD110	21-4, 21-2
HCD120	20-2
HCD130	21-2, 21-3
HCD140	10
HCD150	10
HCD160	10
HCD170	10
HCD180	10
HCD190	10
HCD200	10
HCD210	10
HCD220	10
HCD230	10
HCD240	10
HCD250	10
HCD260	10
HCD270	10
HCD280	10
HCD290	10
HCD300	10
HCD310	10
HCD320	10
HCD330	10

OUTPUT	
	FO-SH
HCD340	10
HCD350	10
HCD360	10
HCD370	10
HCD380	10
HCD390	10
HCD400	10
HCD410	10
HCD420	10
HCD430	10
HCD440	10
HCD450	10
HCD460	10
HCD470	10
HCD480	10
HCD490	10
HCD500	10
HCD510	10
HCD520	10
HCD530	10
HCD540	10
HCD550	10
HCD560	10
HCD570	10
HCD580	10
HCD590	10
HCD600	10
HCD610	10
HCD620	10
HCD630	10
HCD640	10
HCD650	10
HCD660	10
HCD670	10
HCD680	10
HCD690	10
HCD700	10
HCD710	10

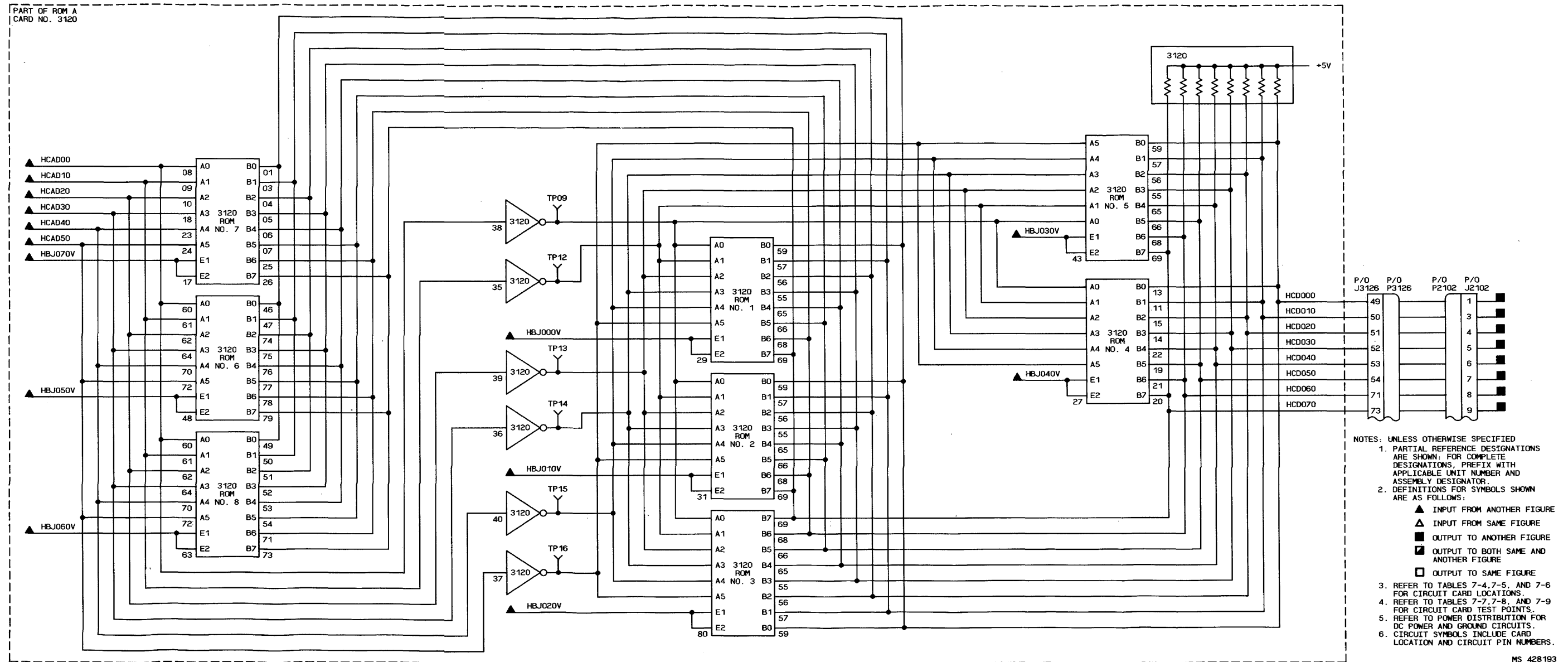

- NOTES: UNLESS OTHERWISE SPECIFIED
- PARTIAL REFERENCE DESIGNATIONS ARE SHOWN. FOR COMPLETE DESIGNATIONS, PREFIX WITH APPLICABLE UNIT NUMBER AND ASSEMBLY DESIGNATOR.
  - DEFINITIONS FOR SYMBOLS SHOWN ARE AS FOLLOWS:
    - ▲ INPUT FROM ANOTHER FIGURE
    - ▲ INPUT FROM SAME FIGURE
    - OUTPUT TO ANOTHER FIGURE
    - OUTPUT TO BOTH SAME AND ANOTHER FIGURE
    - OUTPUT TO SAME FIGURE
  - REFER TO TABLES 7-4, 7-5, AND 7-6 FOR CIRCUIT CARD LOCATIONS.
  - REFER TO TABLES 7-7, 7-8, AND 7-9 FOR CIRCUIT CARD TEST POINTS.
  - REFER TO POWER DISTRIBUTION FOR DC POWER AND GROUND CIRCUITS.
  - CIRCUIT SYMBOLS INCLUDE CARD LOCATION AND CIRCUIT PIN NUMBERS.

FO-11. Test Pattern Memory Logic Diagram (Sheet 1 of 8)



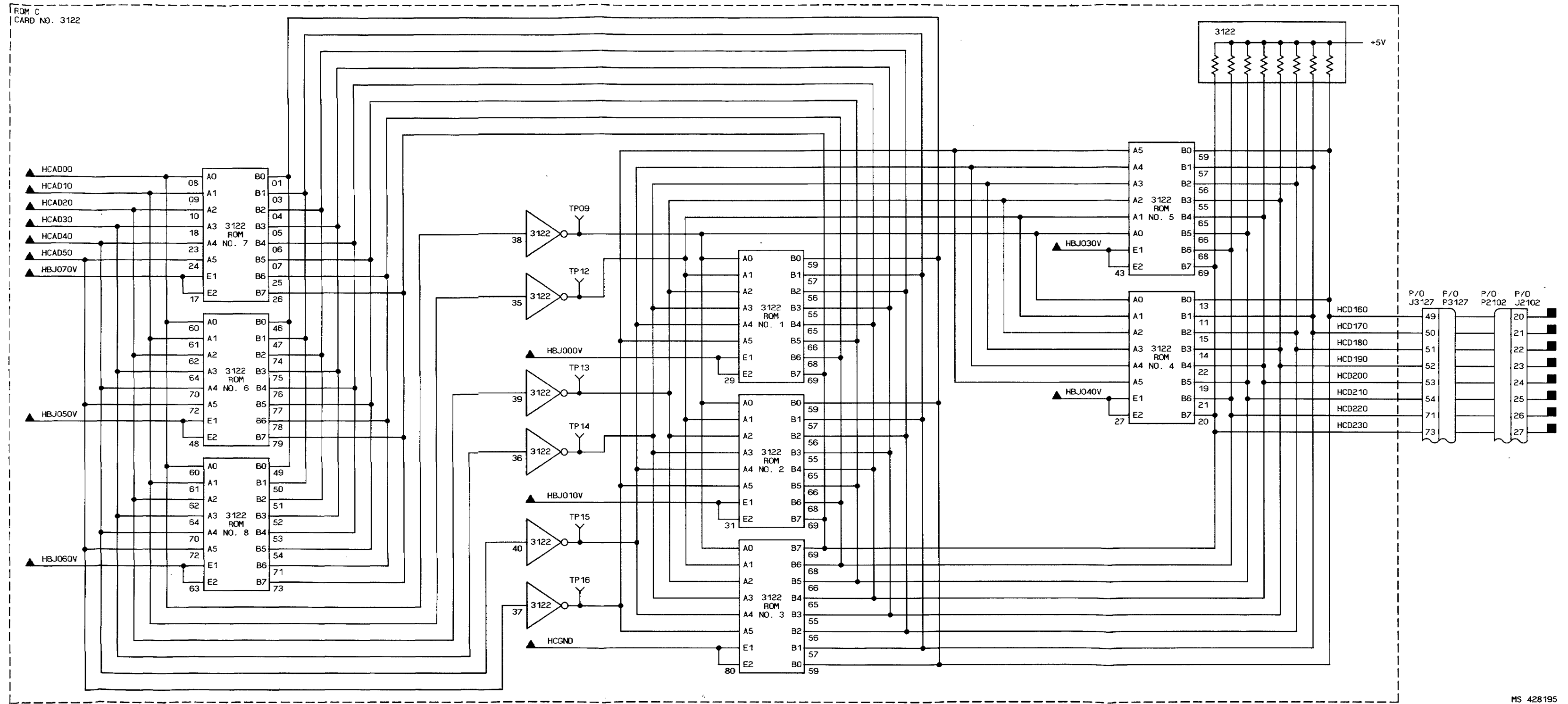

MS 428195

FO-11. Test Pattern Memory Logic Diagram (Sheet 3 of 8)

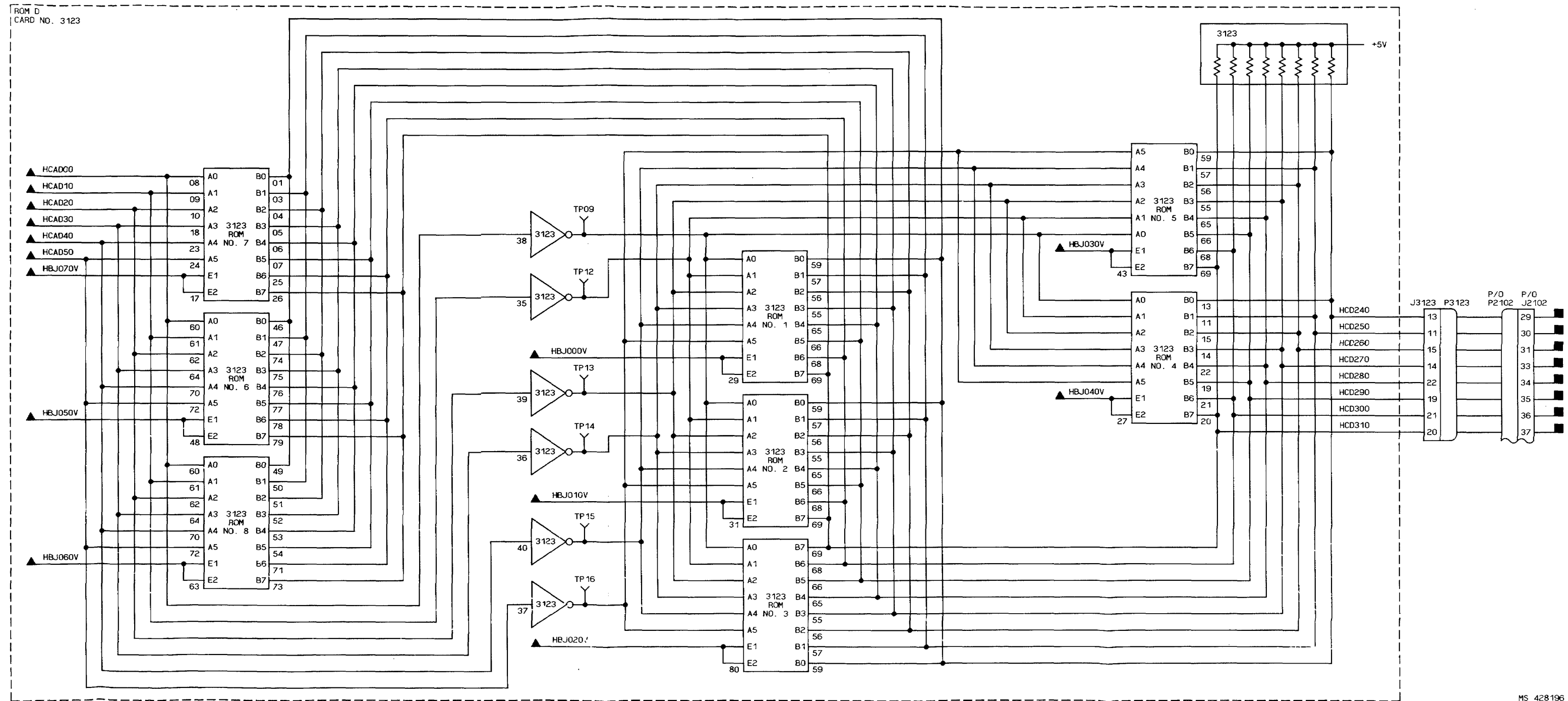

MS 428196

FO-11. Test Pattern Memory Logic Diagram (Sheet 4 of 8)

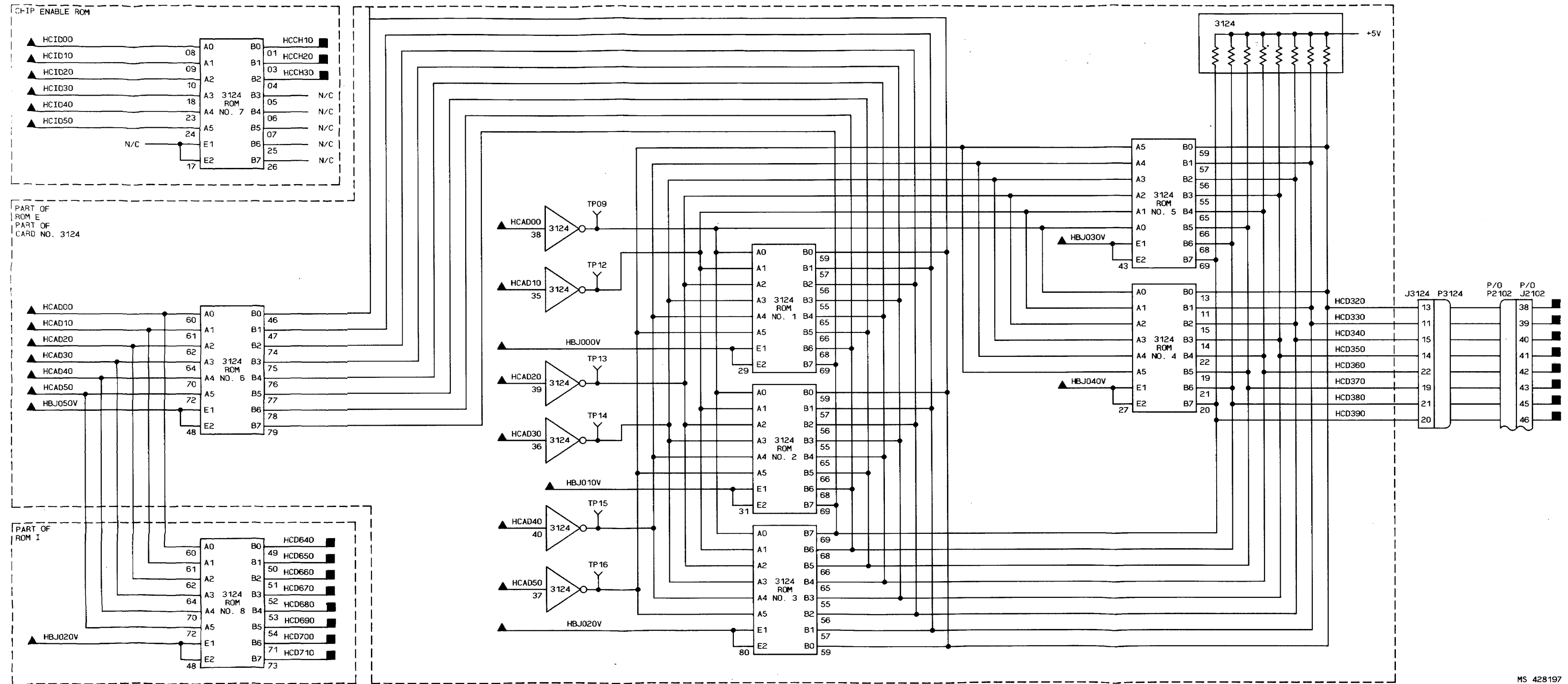

MS 428197

FO-11. Test Pattern Memory Logic Diagram (Sheet 5 of 8)



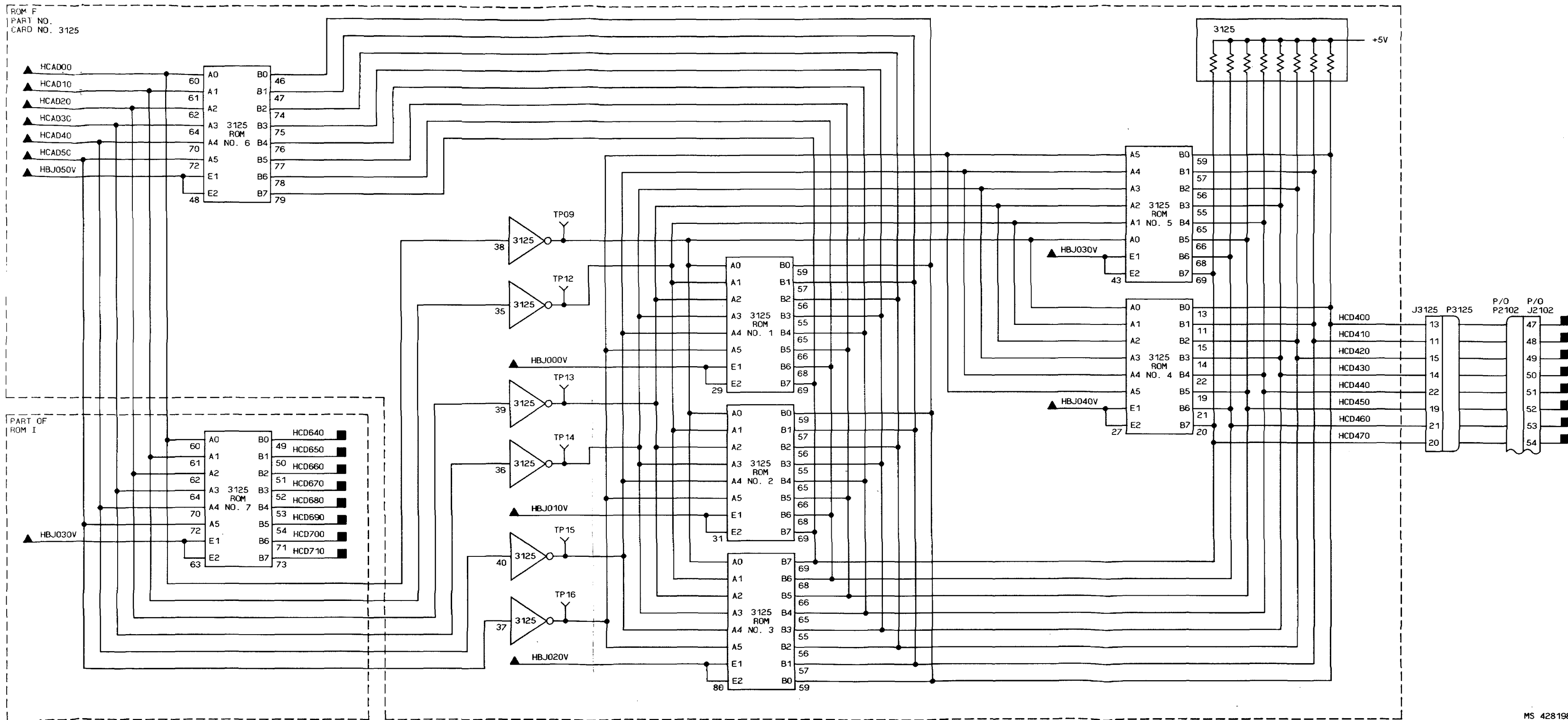

FO-11. Test Pattern Memory Logic Diagram (Sheet 6 of 8)

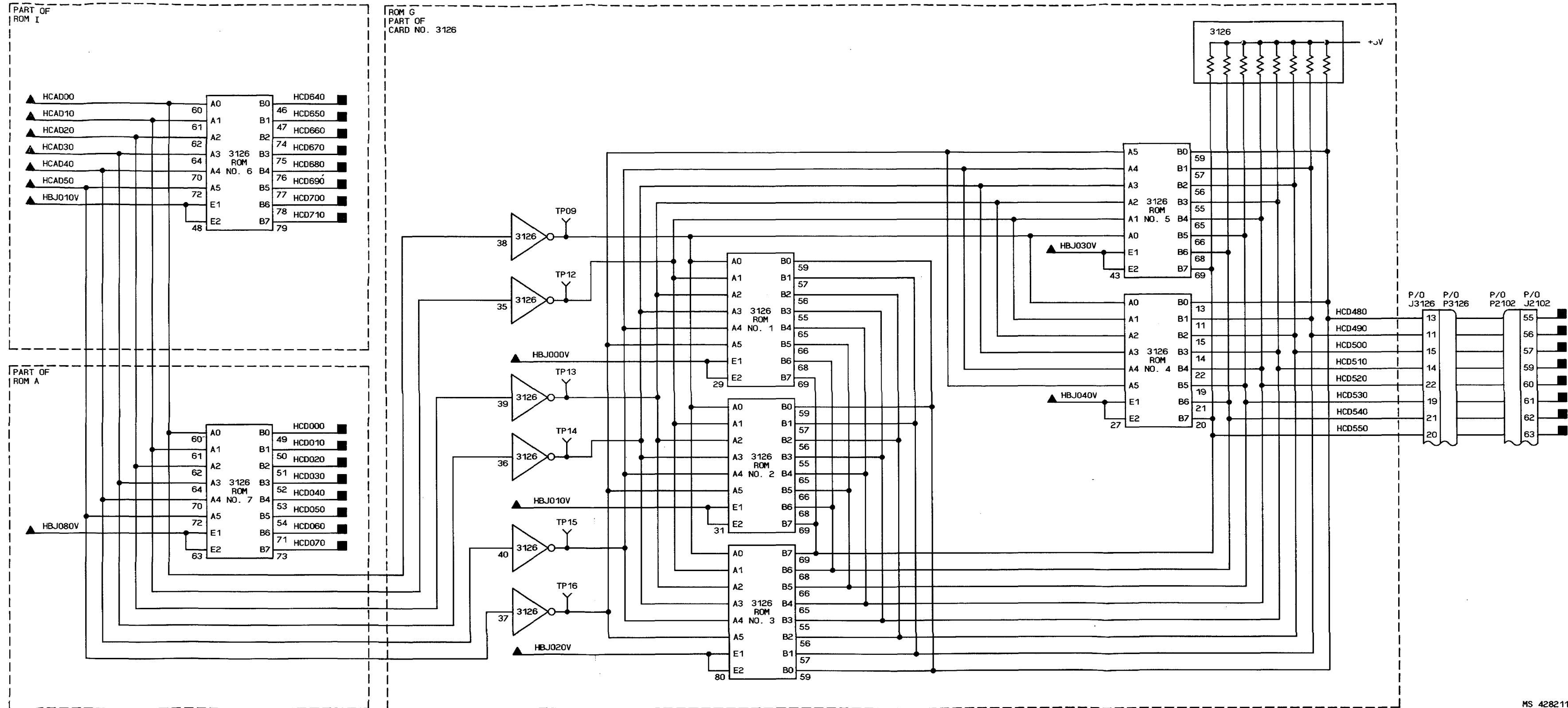

FO-11. Test Pattern Memory Logic Diagram (Sheet 7 of 8)

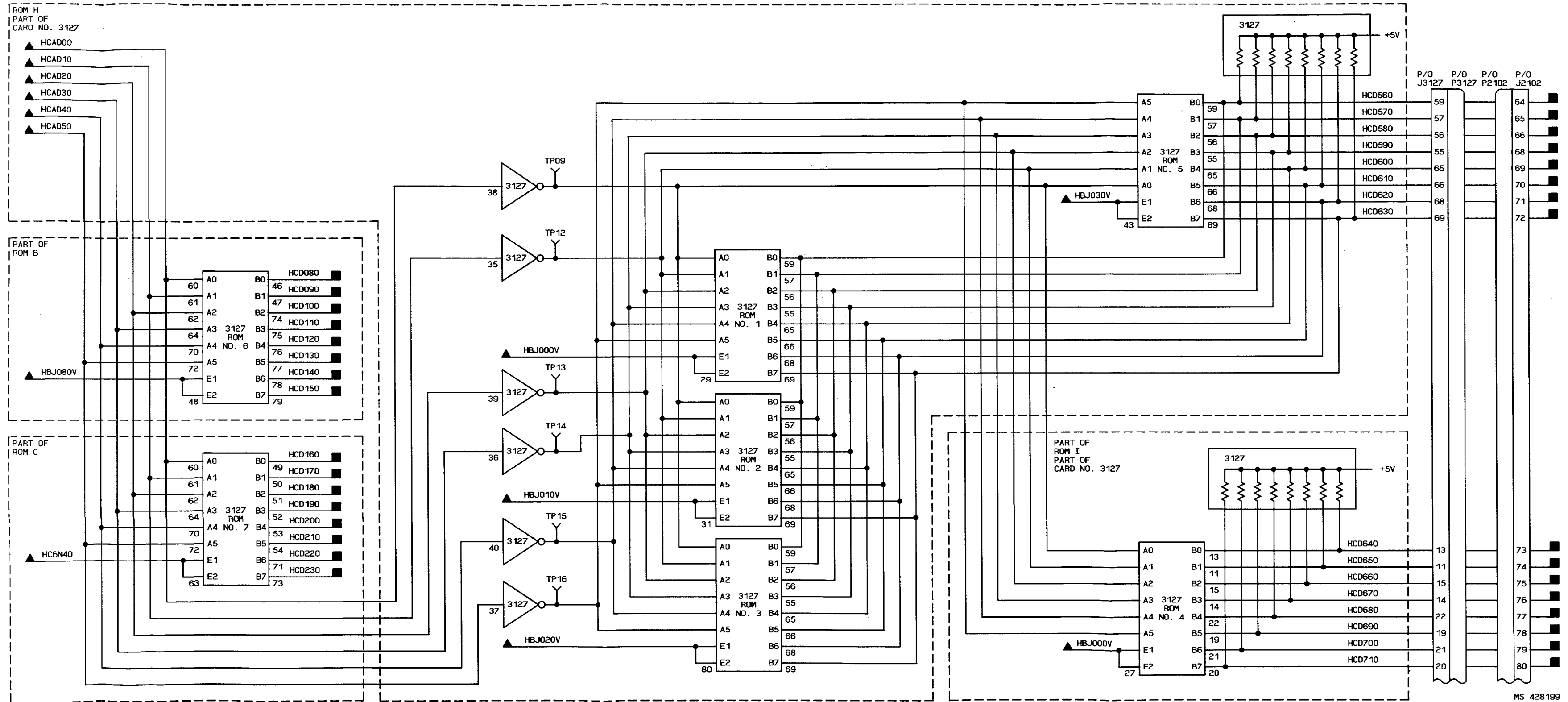

FO-11. Test Pattern Memory Logic Diagram (Sheet 8 of 8)



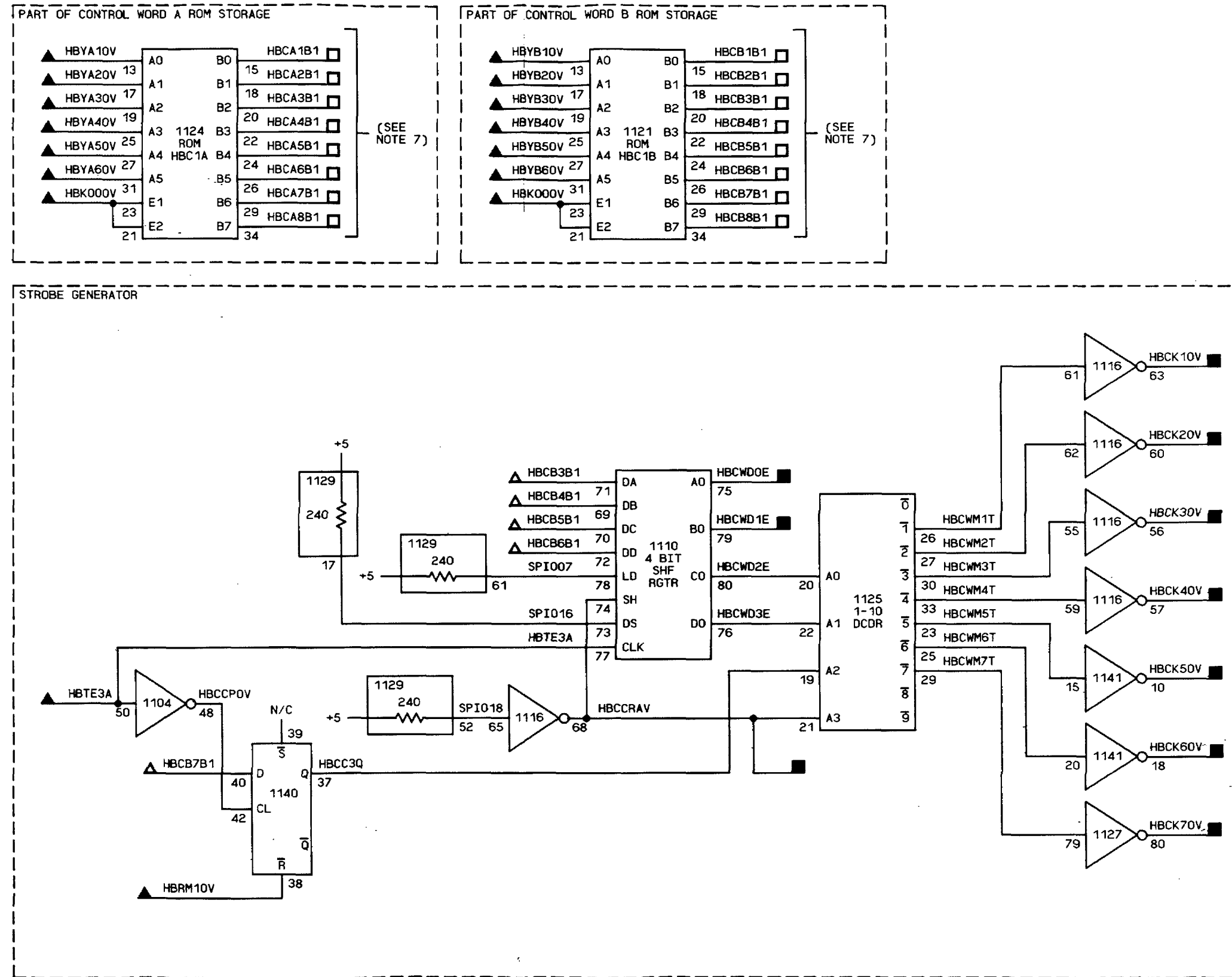

FO-12. Control Word Memory Logic Diagram (Sheet 2 of 3)

MS 428201

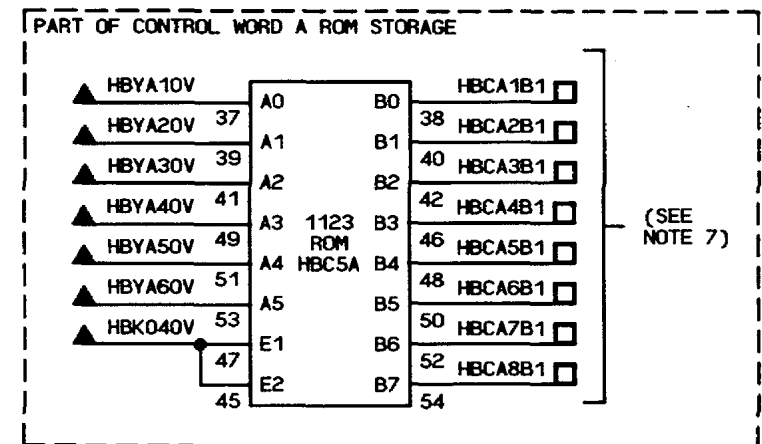
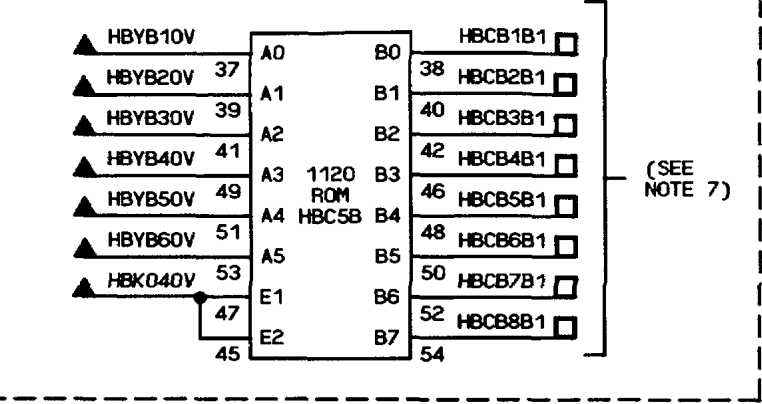
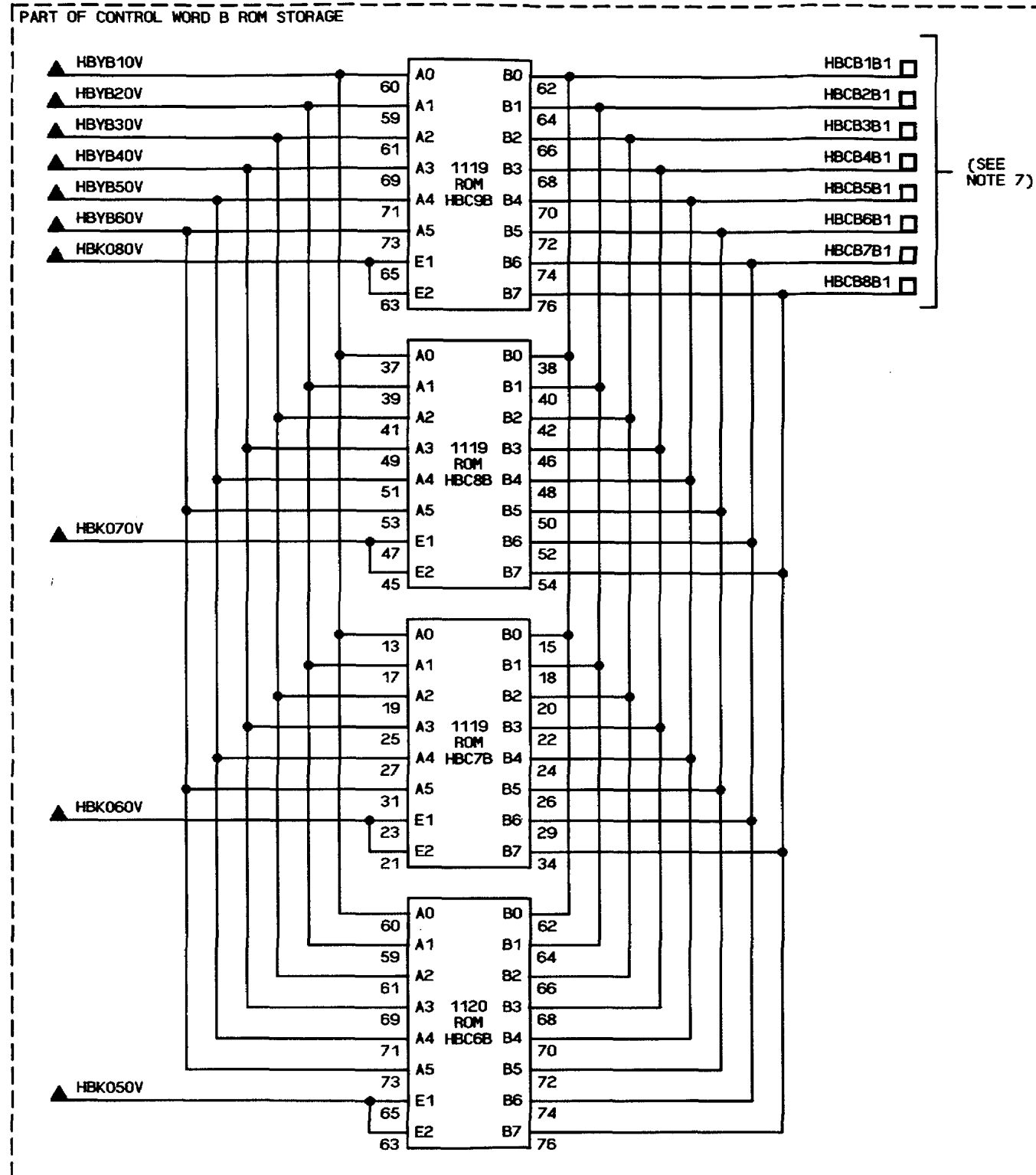
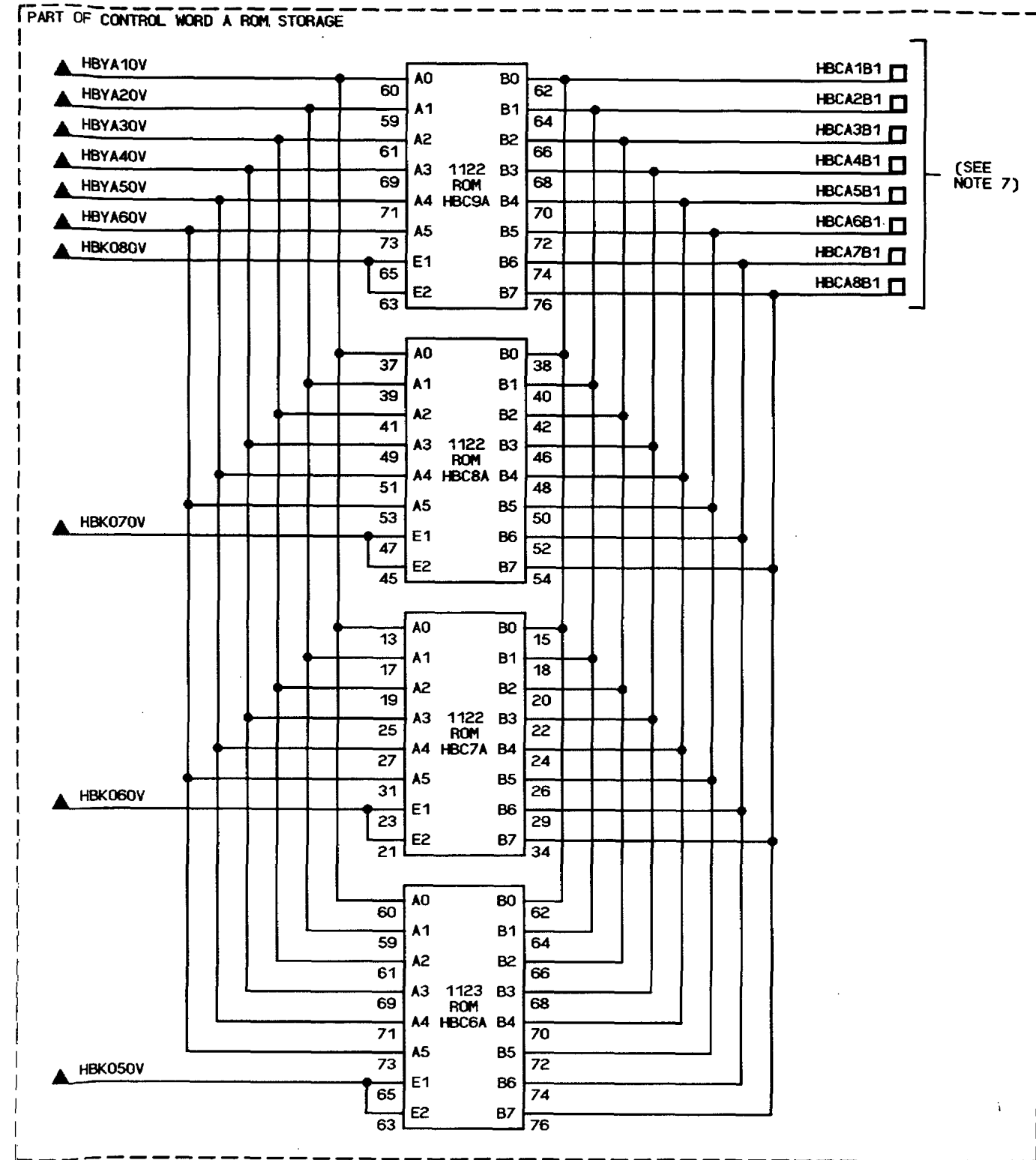

FO-12. Control Word Memory Logic Diagram (Sheet 3 of 3)



INPUT		FO-SH	
HADA00	15-1	HACN00	15-6
HADA01	15-1	HACN01	15-6
HADA02	15-1	HACN02	15-6
HADA03	15-1	HACN03	15-6
HADA04	15-1	HACN04	15-6
HADA05	15-1	HACN05	15-6
HADA06	15-1	HACN06	15-6
HADA07	15-1	HACN07	15-6
HADA08	15-1	HACN08	15-6
HADA09	15-1	HACN09	15-6
HADA10	15-1	HACN10	15-6
HADA11	15-1	HACN11	15-6
HADA12	15-1	HACN12	15-6
HADA13	15-1	HACN13	15-6
HADA14	15-1	HACN14	15-6
HADA15	15-1	HACN15	15-6
HADA16	15-1	HACN16	15-6
HADA17	15-1	HACN17	15-6
HADA18	15-1	HACN18	15-6
HADA19	15-1	HACN19	15-6
HADA20	15-1	HACN20	15-6
HADA21	15-1	HACN21	15-6
HADA22	15-1	HACN22	15-6
HADA23	15-1	HACN23	15-6
HADA24	15-1	HACN24	15-6
HADA25	15-1	HACN25	15-6
HADA26	15-1	HACN26	15-6
HADA27	15-1	HACN27	15-6
HADA28	15-1	HACN28	15-6
HADA29	15-1	HACN29	15-6
HADA30	15-1	HACN30	15-6
HADA31	15-1	HACN31	15-6
HADA32	15-1	HACN32	15-6
HADA33	15-1	HACN33	15-6
HADA34	15-1	HACN34	15-6
HADA35	15-1	HACN35	15-6
HADA36	15-1	HACN36	15-6
HADA37	15-1	HACN37	15-6
HADA38	15-1	HACN38	15-6
HADA39	15-1	HACN39	15-6
HADA40	15-1	HACN40	15-6
HADA41	15-1	HACN41	15-6
HADA42	15-1	HACN42	15-6
HADA43	15-1	HACN43	15-6
HADA44	15-1	HACN44	15-6
HADA45	15-1	HACN45	15-6
HADA46	15-1	HACN46	15-6
HADA47	15-1	HACN47	15-6
HADA48	15-1	HACN48	15-6
HADA49	15-1	HACN49	15-6
HADA50	15-1	HACN50	15-6
HADA51	15-1	HACN51	15-6
HADA52	15-1	HACN52	15-6
HADA53	15-1	HACN53	15-6
HADA54	15-1	HACN54	15-6
HADA55	15-1	HACN55	15-6
HADA56	15-1	HACN56	15-6
HADA57	15-1	HACN57	15-6
HADA58	15-1	HACN58	15-6
HADA59	15-1	HACN59	15-6
HADA60	15-1	HACN60	15-6
HADA61	15-1	HACN61	15-6
HADA62	15-1	HACN62	15-6
HADA63	15-1	HACN63	15-6
HADA64	15-1	HACN64	15-6
HADA65	15-1	HACN65	15-6
HADA66	15-1	HACN66	15-6
HADA67	15-1	HACN67	15-6
HADA68	15-1	HACN68	15-6
HADA69	15-1	HACN69	15-6
HADA70	15-1	HACN70	15-6
HADA71	15-1	HACN71	15-6
HADA72	15-1	HACN72	15-6
HADA73	15-1	HACN73	15-6
HADA74	15-1	HACN74	15-6
HADA75	15-1	HACN75	15-6
HADA76	15-1	HACN76	15-6
HADA77	15-1	HACN77	15-6
HADA78	15-1	HACN78	15-6
HADA79	15-1	HACN79	15-6
HADA80	15-1	HACN80	15-6
HADA81	15-1	HACN81	15-6
HADA82	15-1	HACN82	15-6
HADA83	15-1	HACN83	15-6
HADA84	15-1	HACN84	15-6
HADA85	15-1	HACN85	15-6
HADA86	15-1	HACN86	15-6
HADA87	15-1	HACN87	15-6
HADA88	15-1	HACN88	15-6
HADA89	15-1	HACN89	15-6
HADA90	15-1	HACN90	15-6
HADA91	15-1	HACN91	15-6
HADA92	15-1	HACN92	15-6
HADA93	15-1	HACN93	15-6
HADA94	15-1	HACN94	15-6
HADA95	15-1	HACN95	15-6
HADA96	15-1	HACN96	15-6
HADA97	15-1	HACN97	15-6
HADA98	15-1	HACN98	15-6
HADA99	15-1	HACN99	15-6
HADA00	15-1	HACN00	15-6

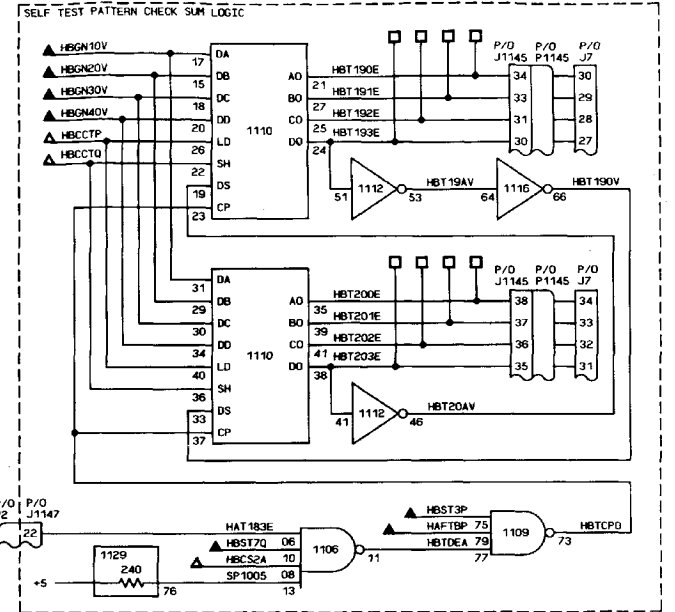
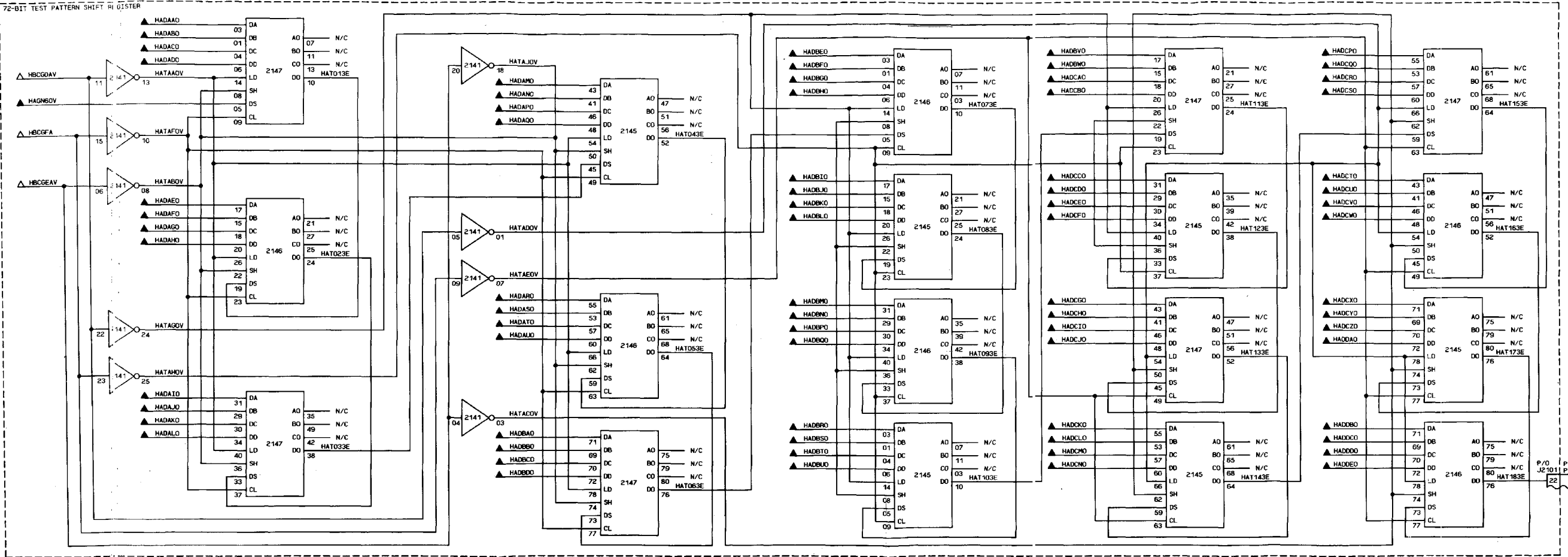

- NOTES: UNLESS OTHERWISE SPECIFIED:
- PARTIAL REFERENCE DESIGNATIONS ARE SHOWN. FOR COMPLETE DESIGNATIONS, PREFIX WITH APPLICABLE UNIT NUMBER AND ASSEMBLY DESIGNATOR.
  - DEFINITIONS FOR SYMBOLS SHOWN ARE AS FOLLOWS:
    - ▲ INPUT FROM ANOTHER FIGURE
    - ▲ INPUT FROM SAME FIGURE
    - OUTPUT TO ANOTHER FIGURE
    - OUTPUT TO BOTH SAME AND ANOTHER FIGURE
    - OUTPUT TO SAME FIGURE
  - REFER TO TABLES 7-4, 7-5, AND 7-6 FOR CIRCUIT CARD LOCATION.
  - REFER TO TABLES 7-7, 7-8, AND 7-9 FOR CIRCUIT CARD TEST POINTS.
  - REFER TO POWER DISTRIBUTION FOR DC POWER AND GROUND CIRCUITS.
  - CIRCUIT SYMBOLS INCLUDE CARD LOCATION AND CIRCUIT PIN NUMBERS.

FO-14 Self Test Logic Diagram (Sheet 1 of 2)



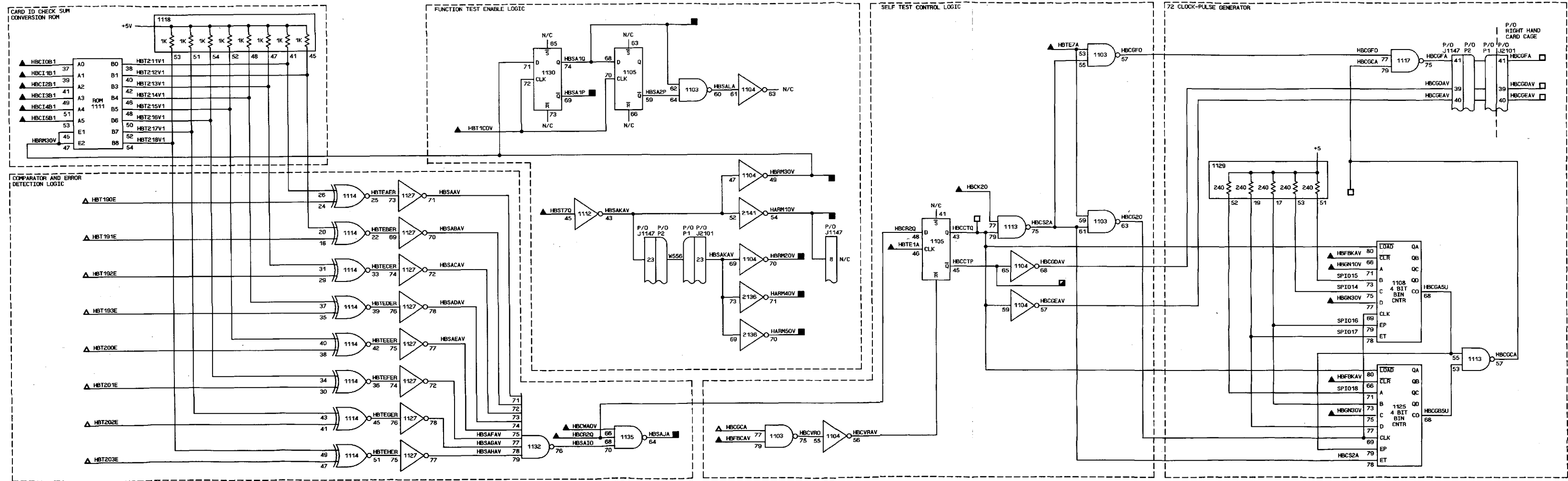

FO-14 Self Test Logic Diagram (Sheet 2 of 2)

MS 428205





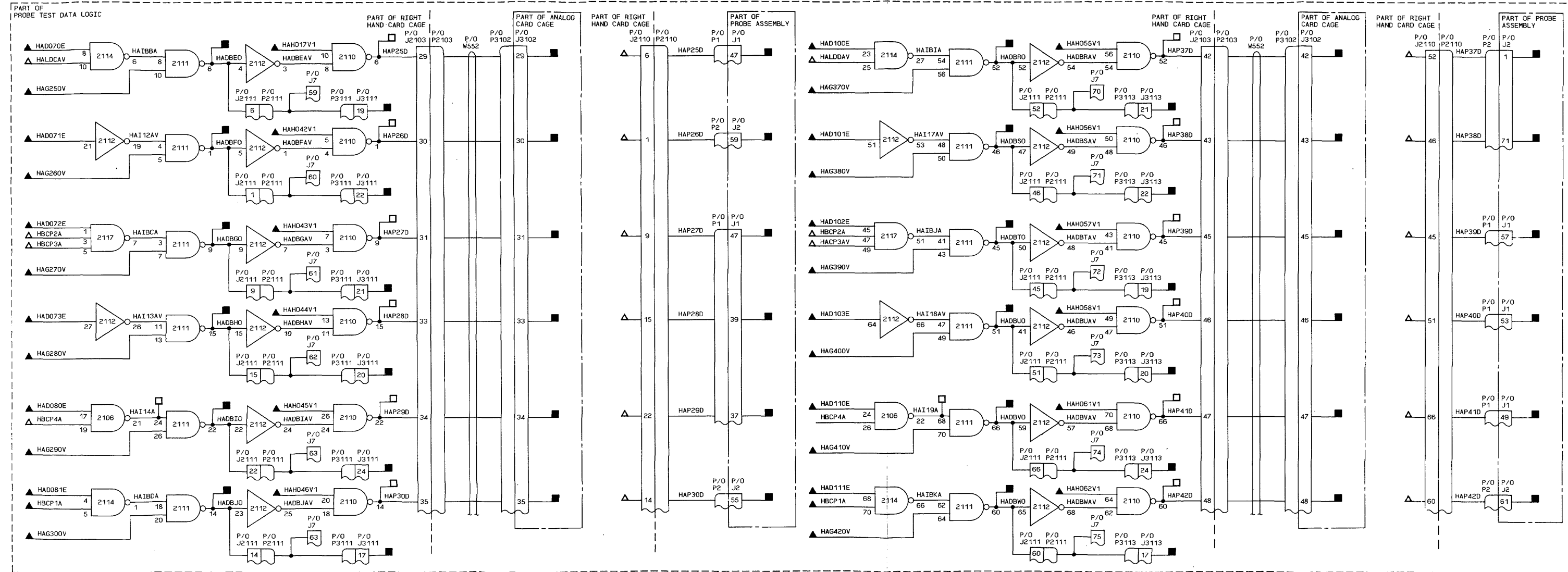

MS 428208

FO-15. Probe Control Logic Diagram (Sheet 3 of 7)



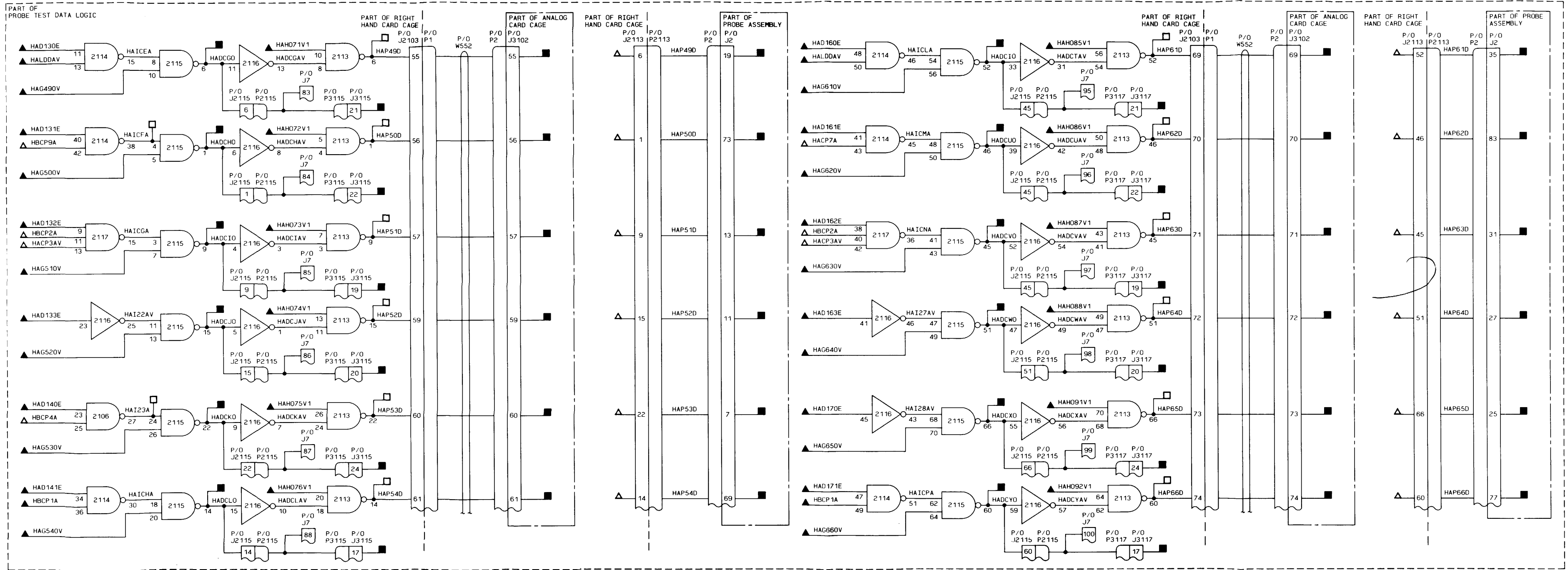

MS 428291

FO-15. Probe Control Logic Diagram (Sheet 5 of 7)

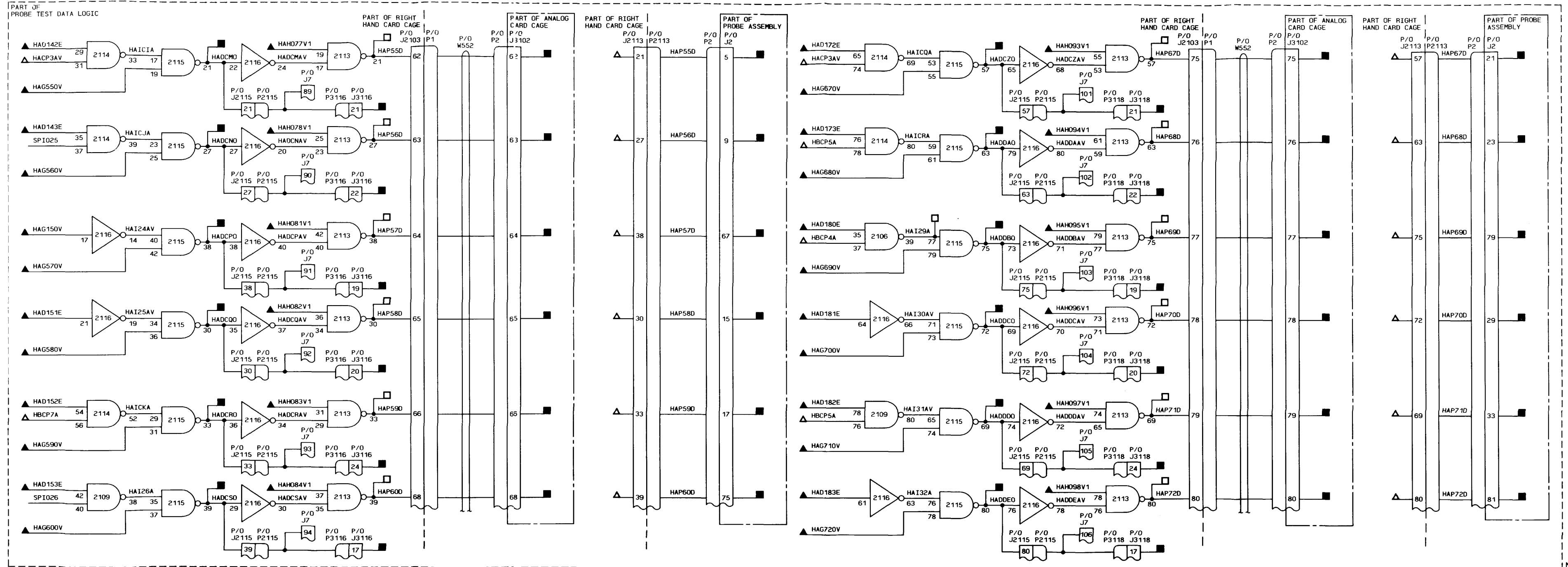

MS 428292

FO-15. Probe Control Logic Diagram (Sheet 6 of 7)





INPUT		OUTPUT	
	FO-SH		FO-SH
HBC10B1	2	HBWA1A	9-1
HBC11B1	2	HBWAVOV	15-7
HBC12B1	2	HBWAPOV	15-7
HBC13B1	2	HBWAQOV	15-7
HBC14B1	2	HBWASOV	15-7
HBC15B1	2	HBWATOV	15-7
HBC15B1	2	HBWAVOV	13
HBFACR	18-2	HBWAVOV	15-7
HBSTSP	18-1	HBWAVOV	18-2, 19
HBST15Q	18-1	HBWAVOV	18-2, 19
HBGN10V	23	HBWAVOV	18-2, 19
HBGN20V	23	HBWAVOV	18-2, 19
HBST1AV	18-1	HBWAKA	6-4, 6-5
		HBWAVOV	15-7
		HBWAVOV	9-1
		HBWBBOV	18-3
		HBWBCA	19
		HBWBD A	19
		HBWBD B	19
		HBWCS	19

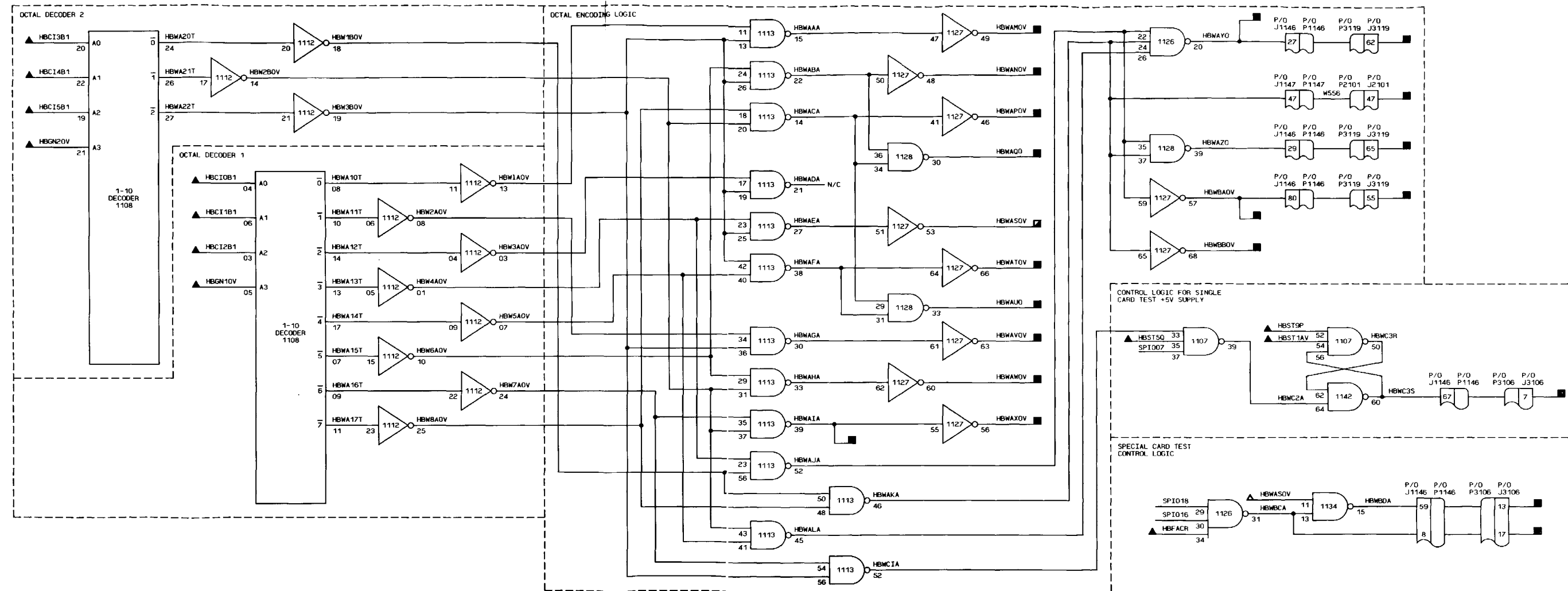

- NOTES: UNLESS OTHERWISE SPECIFIED
- PARTIAL REFERENCE DESIGNATIONS ARE SHOWN. FOR COMPLETE DESIGNATIONS, PREFIX WITH APPLICABLE UNIT NUMBER AND ASSEMBLY DESIGNATOR.
  - DEFINITIONS FOR SYMBOLS SHOWN ARE AS FOLLOWS:
    - ▲ INPUT FROM ANOTHER FIGURE
    - △ INPUT FROM SAME FIGURE
    - OUTPUT TO ANOTHER FIGURE
    - ◼ OUTPUT TO BOTH SAME AND ANOTHER FIGURE
    - OUTPUT TO SAME FIGURE
  - REFER TO TABLES 7-4, 7-5, AND 7-6 FOR CIRCUIT CARD LOCATIONS.
  - REFER TO TABLES 7-7, 7-8, AND 7-9 FOR CIRCUIT CARD TEST POINTS.
  - REFER TO POWER DISTRIBUTION FOR DC POWER AND GROUND CIRCUITS.
  - CIRCUIT SYMBOLS INCLUDE CARD LOCATION AND CIRCUIT PIN NUMBERS.

FO-16. Card ID Decode for Clock Insertion Logic Diagram



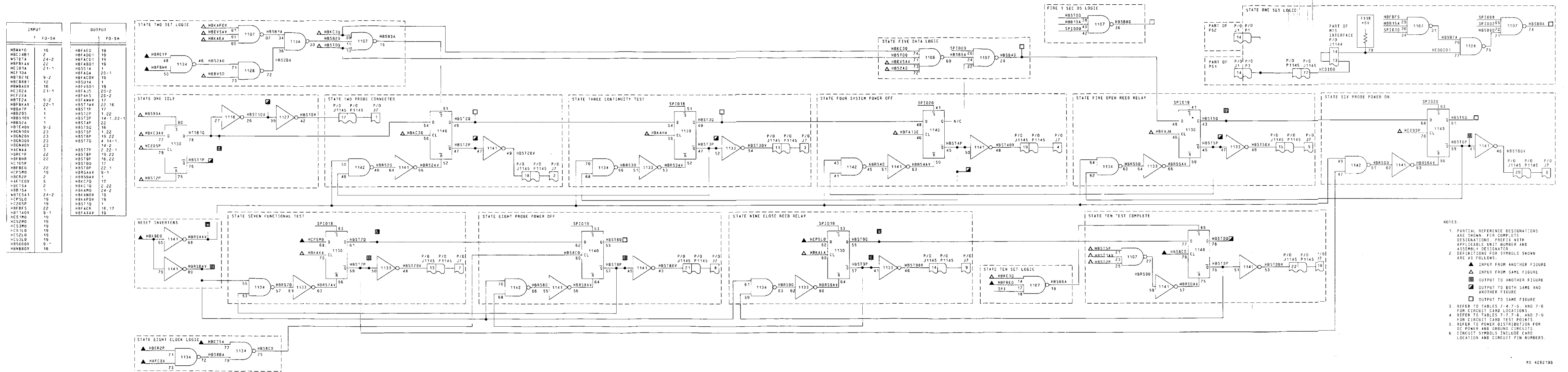

FO-18. State Logic Diagram (Sheet 1 of 3)  
Change 2



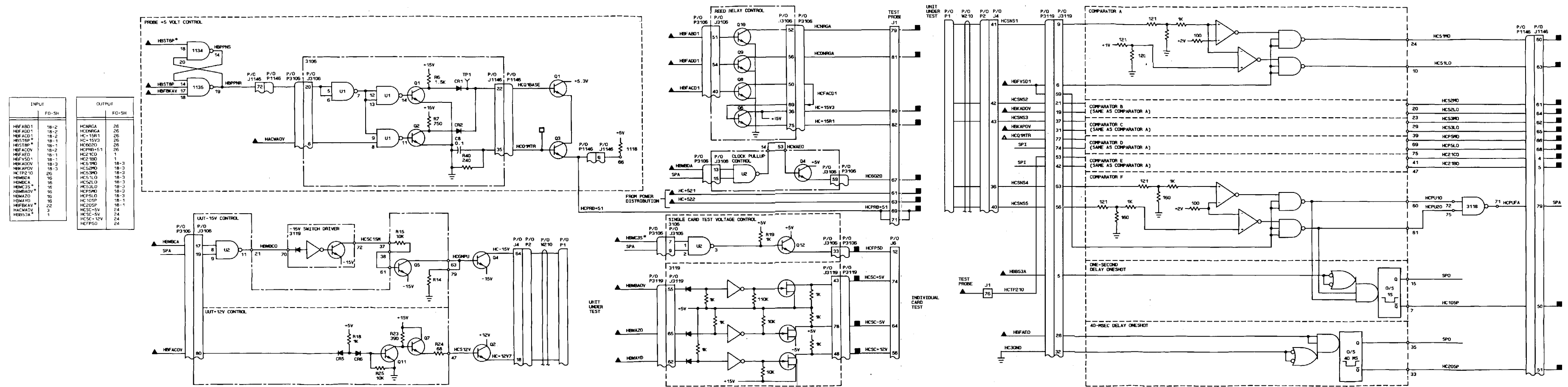

FO-19. Special Card Test Logic Diagram

INPUT	
	FO-SH
HBFAGA	18-2
HBLAGA	13
HCH20	11-5
HCCR1A	21-1, 21-2
HCCR2A	21-2, 21-3
HCCR3A	21-2, 21-3
HCCR4A	21-3, 21-4
HCCR5A	21-3, 21-4
HCCR6A	21-4
HCF01A	21-1, 21-2
HCF02A	21-2, 21-3
HCF03A	21-2, 21-3
HCF04A	21-3, 21-4
HCF05A	21-3, 21-4
HCF06A	21-4
HCF11A	21-1, 21-2
HCF12A	21-2, 21-3
HCF13A	21-2, 21-3
HCF14A	21-3, 21-4
HCF15A	21-3, 21-4
HCF16A	21-4
HCF629A	21-3
HCH629A	21-3
HBFBR01	22-1
HBFAS	18-2
HBFAS	18-2
HCF0Z1	23
HCF0Z2	23
HCF0Z3	23
HCF0Z4	23
HCF0Z5	23
HCF0Z6	23
HCFZ1	23
HCFZ2	23
HCFZ3	23
HCFZ4	23
HCFZ5	23
HCFZ6	23
HCFI21	23
HCFI22	23
HCFI23	23
HCFI24	23
HCFI25	23
HCFI26	23

OUTPUT	
	FO-SH
HCE01A	17
HCE02A	17
HCE03A	17
HCE04A	17
HCE05A	17
HCE06A	17
HCE07A	17
HCE08A	17
HCE09A	17
HCE10A	17
HCE11A	17
HCE12A	17
HCE13A	17
HCE14A	17
HCE15A	17
HCE16A	17
HCE17A	17
HCE18A	17
HCF0Z1	24
HCF0Z2	24
HCF0Z3	24
HCF0Z4	24
HCF0Z5	24
HCF0Z6	24
HCCFZ1	24
HCCFZ2	24
HCCFZ3	24
HCCFZ4	24
HCCFZ5	24
HCCFZ6	24
HCFI21	24
HCFI22	24
HCFI23	24
HCFI24	24
HCFI25	24
HCFI26	24

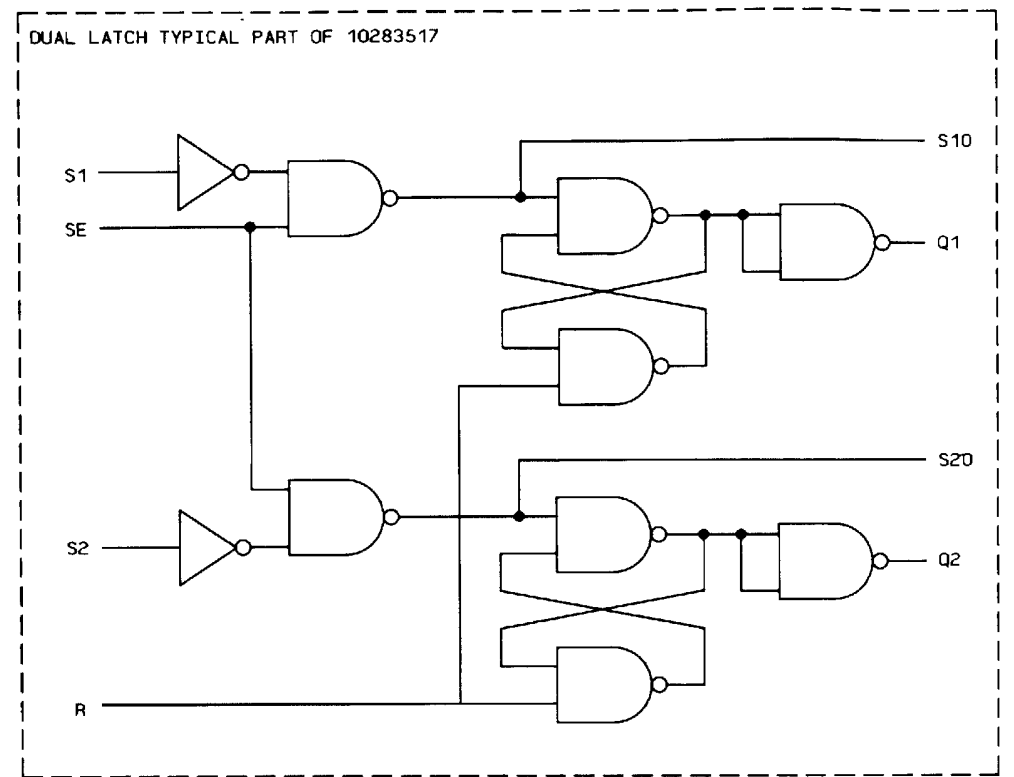
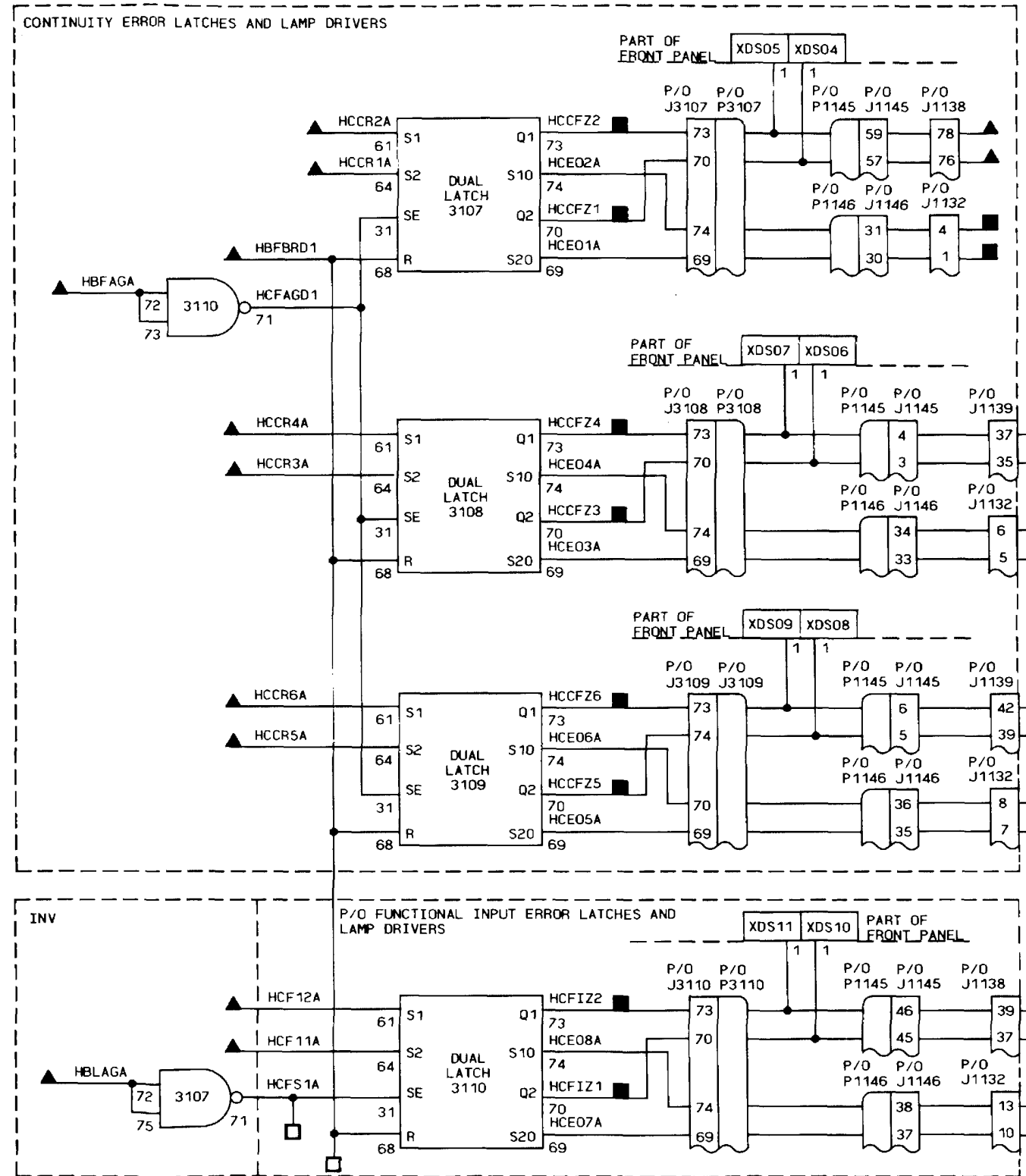

- NOTES: UNLESS OTHERWISE SPECIFIED
- PARTIAL REFERENCE DESIGNATIONS ARE SHOWN; FOR COMPLETE DESIGNATIONS, PREFIX WITH APPLICABLE UNIT NUMBER AND ASSEMBLY DESIGNATOR.
  - DEFINITIONS FOR SYMBOLS SHOWN ARE AS FOLLOWS:
    - ▲ INPUT FROM ANOTHER FIGURE
    - △ INPUT FROM SAME FIGURE
    - OUTPUT TO ANOTHER FIGURE
    - ◻ OUTPUT TO BOTH SAME AND ANOTHER FIGURE
    - OUTPUT TO SAME FIGURE
  - REFER TO TABLES 7-4, 7-5, AND 7-6 FOR CIRCUIT CARD LOCATIONS.
  - REFER TO TABLES 7-7, 7-8, AND 7-9 FOR CIRCUIT CARD TEST POINTS.
  - REFER TO POWER DISTRIBUTION FOR DC POWER AND GROUND CIRCUITS.
  - CIRCUIT SYMBOLS INCLUDE CARD LOCATION AND CIRCUIT PIN NUMBERS.

FO-20. Lamp Driver Logic Diagram (Sheet 1 of 2)

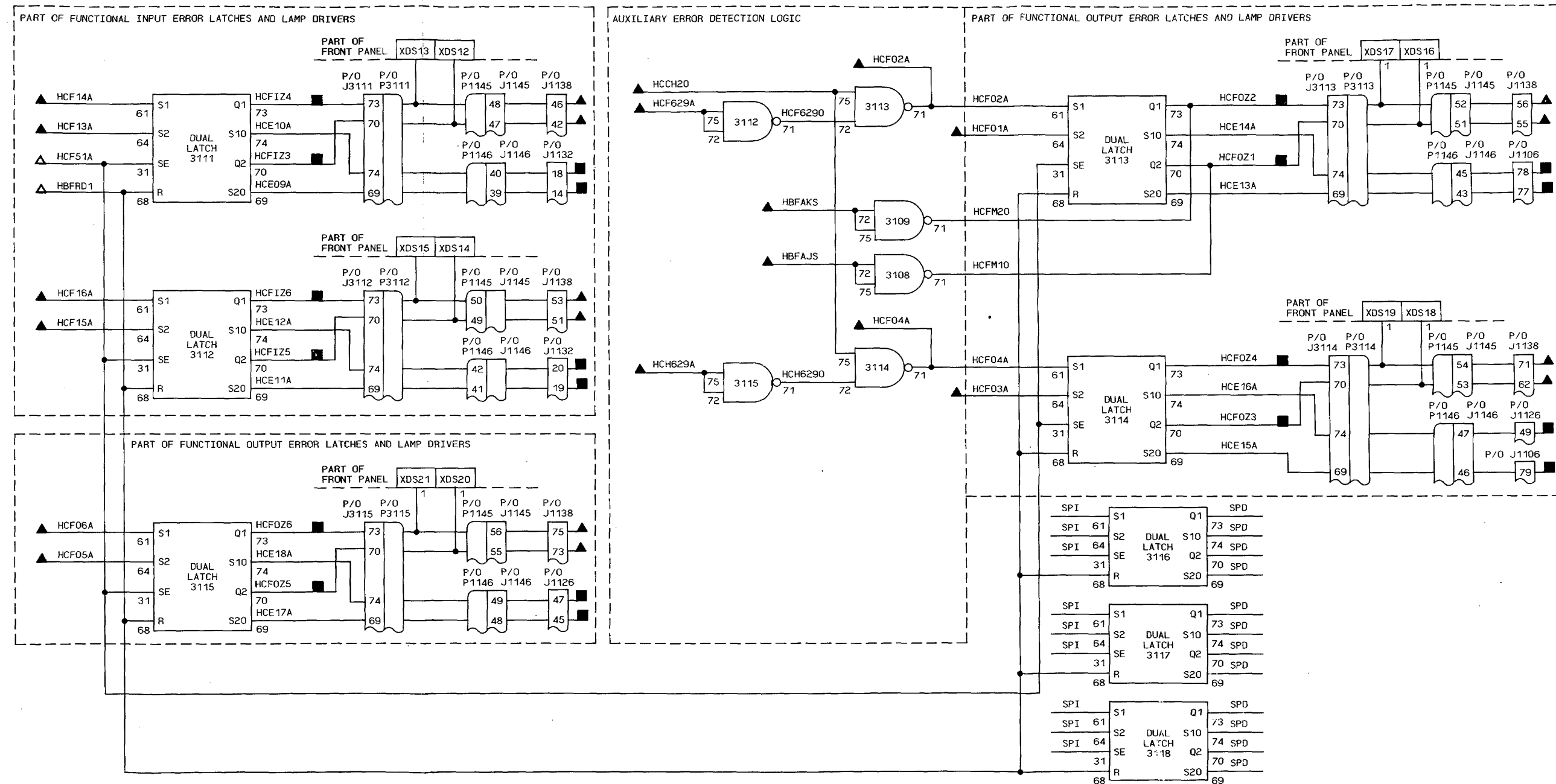

FO-20. Lamp Driver Logic Diagram (Sheet 2 of 2)

MS 428295





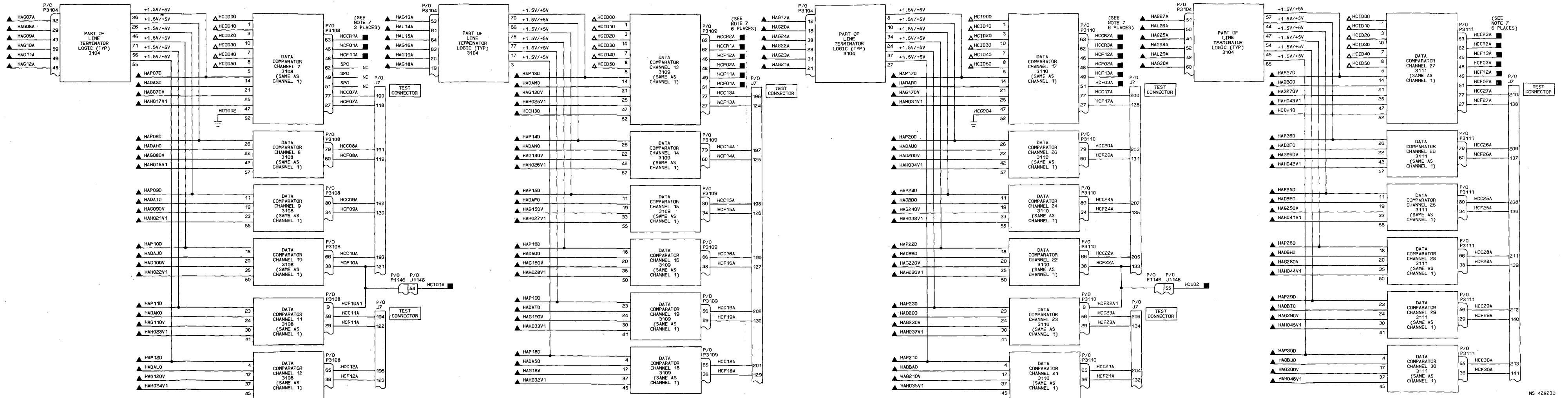

FO-21. Data Compare Logic Diagram (Sheet 2 of 4)

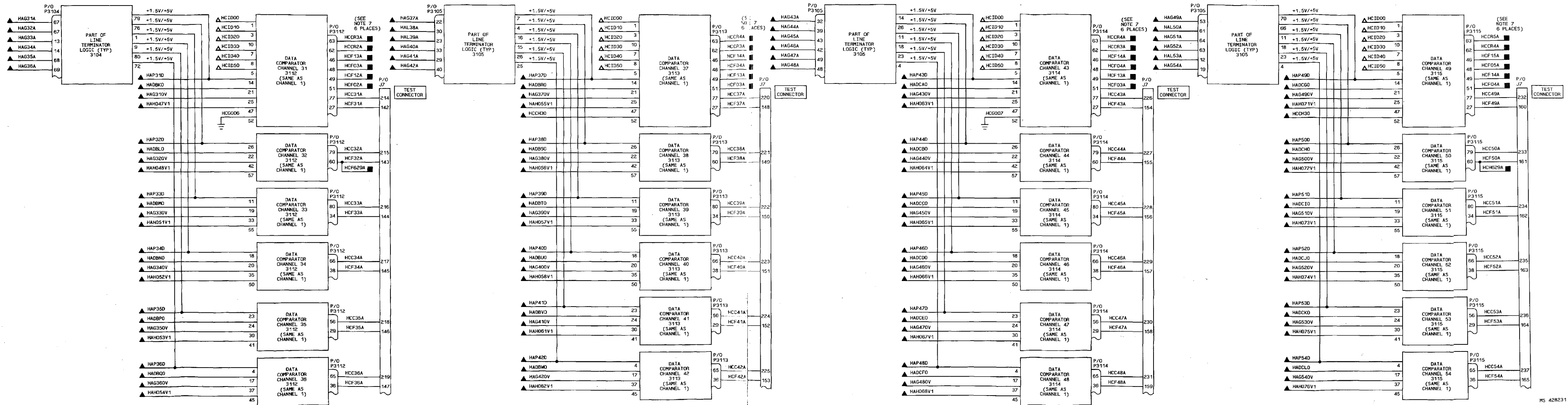

FO-21 Data Compare Logic Diagram (Sheet of 3 of 4)

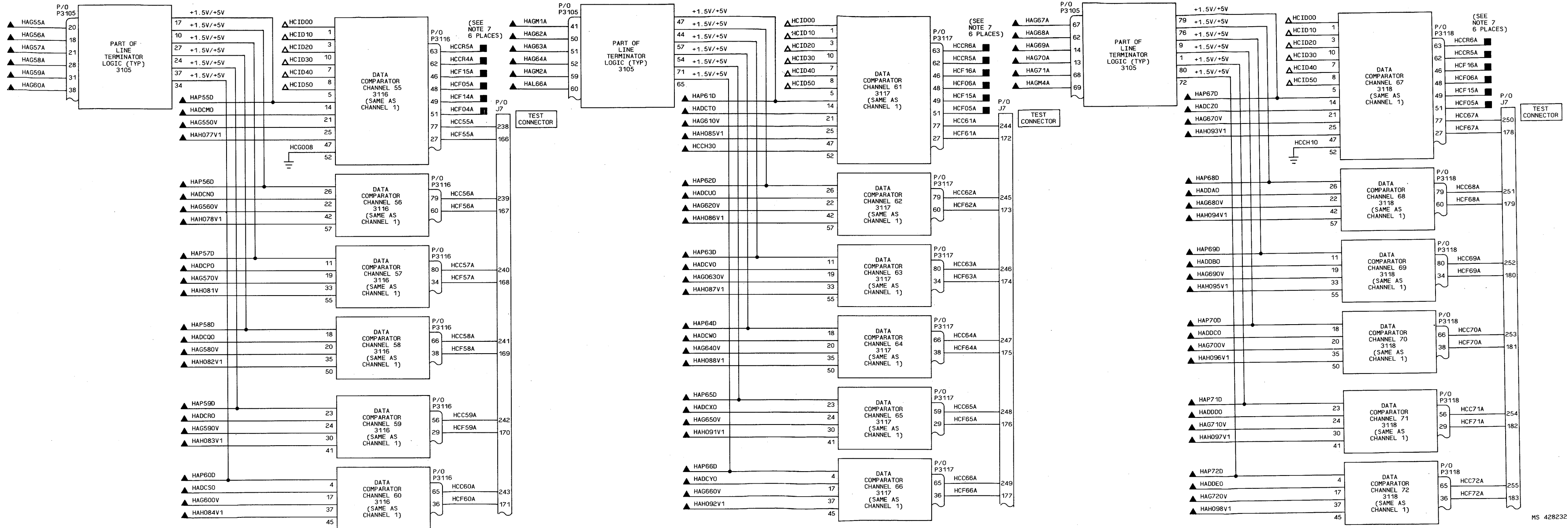

FO-21. Data Compare Logic Diagram (Sheet 4 of 4)

INPUT	
	FO-SH
HKCC1Q	18-3
HBSTOP	18-1
HBCASA	2
HBCID8V1	2
HBCTRAV	2
HBST2P	18-1
HBST3P	18-1
HBST4P	18-1
HBST5P	18-1
HBST6P	18-1
HBST7P	18-1
HBST8P	18-1
HBST9P	18-1
WBCCRA1	24
WBDRRA1	24
WBORSA1	24
WBRCRA1	24
WBSCSA1	24
WBSTRA1	24
WBSTSA1	24
HBST1AV	18-1

OUTPUT	
	FO-SH
HAFBAAV	5
HBFBDAV	2, 4, 14-2, 9-1, 19
HBFBDAV	13
HBFBFR	17
HBFBHR	18-1
HBFBKAV	18-2, 19
HBFB1P	2, 7
HBFCYP	17, 18-1
HBFBEO	18-1
HBFBFS	18-1
HBFBRD1	20-1

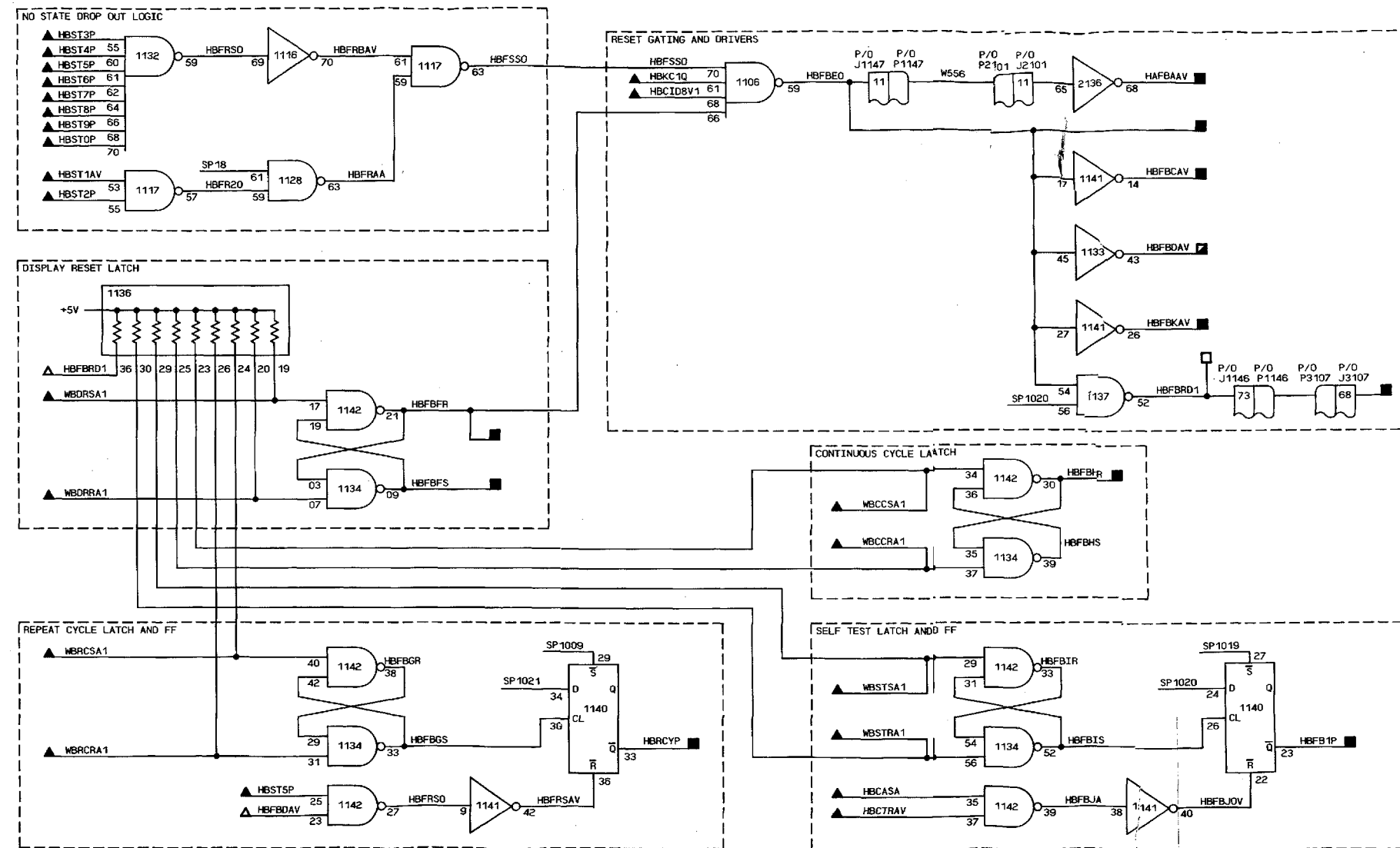

- NOTES: UNLESS OTHERWISE SPECIFIED
- PARTIAL REFERENCE DESIGNATIONS ARE SHOWN; FOR COMPLETE DESIGNATIONS, PREFIX WITH APPLICABLE UNIT NUMBER AND ASSEMBLY DESIGNATOR.
  - DEFINITIONS FOR SYMBOLS SHOWN ARE AS FOLLOWS:
    - ▲ INPUT FROM ANOTHER FIGURE
    - ▲ INPUT FROM SAME FIGURE
    - OUTPUT TO ANOTHER FIGURE
    - OUTPUT TO BOTH SAME AND ANOTHER FIGURE
    - OUTPUT TO SAME FIGURE
  - REFER TO TABLES 7-4, 7-5, AND 7-6 FOR CIRCUIT CARD LOCATIONS.
  - REFER TO TABLES 7-7, 7-8, AND 7-9 FOR CIRCUIT CARD TEST POINTS.
  - REFER TO POWER DISTRIBUTION FOR DC POWER AND GROUND CIRCUITS.
  - CIRCUIT SYMBOLS INCLUDE CARD LOCATION AND CIRCUIT PIN NUMBERS.

MS 428215

FO-22. Reset Logic Diagram

INPUT		OUTPUT	
	FO-SH		FO-SH
HBJRC06	17	HAGN50V	3
HBJAP06	17	HAGN60V	3, 14-1
JBJAQ06	17	HBGN10V	9-1, 9-2, 14-1, 14-2
HBJAR0V	17		16, 18-2
HBJAS06	17	HBGN20V	9-2, 14-1, 14-2, 18-2
HEMY1AV	4	HBGN30V	4, 9-2, 14-1, 14-2
HEMY2AV	4	HBGN40V	18-2, 4, 9-2, 14-1
HEMY3AV	4	HCAD00	11-1 THRU 11-8
HEMY4AV	4	HCDA10	11-1 THRU 11-8
HEMY5AV	4	HCDA20	11-1 THRU 11-8
HEMY6AV	4	HCDA30	11-1 THRU 11-8
HBCSTD6	2	HCDA40	11-1 THRU 11-8
WBLTEA1	24	HCDA50	11-1 THRU 11-8
WBLTA6	24	HBJAPD6	26
WBLFTA6	24	HBJAR06	26
		HCFIZ1	20
		HCFIZ2	20
		HCFIZ3	20
		HCFIZ4	20
		HCFIZ5	20
		HCFIZ6	20
		HCCFZ1	20
		HCCFZ2	20
		HCCFZ3	20
		HCCFZ4	20
		HCCFZ5	20
		HCCFZ6	20
		HCFDZ1	20
		HCFDZ2	20
		HCFDZ3	20
		HCFDZ4	20
		HCFDZ5	20
		HCFDZ6	20

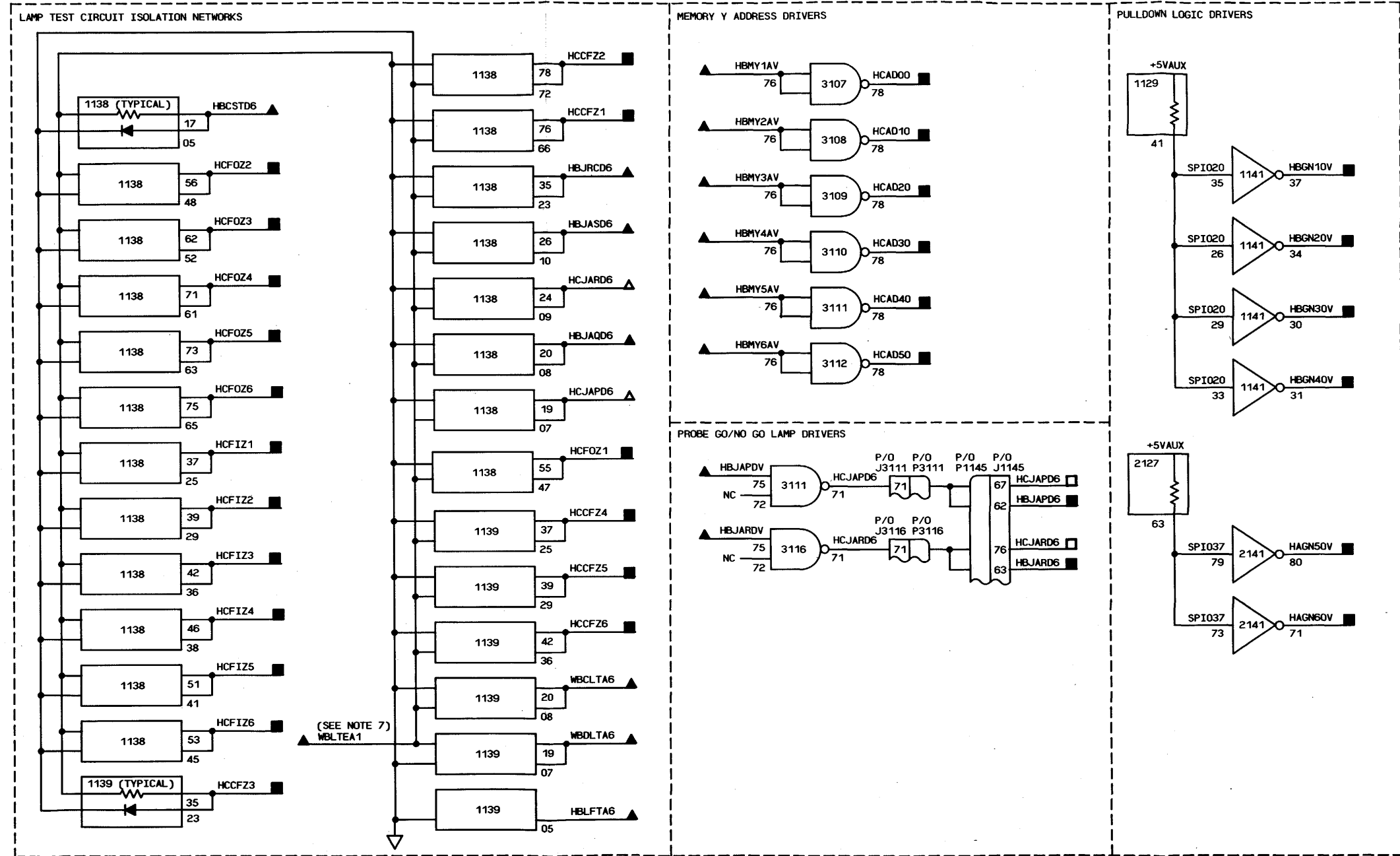

- NOTES: UNLESS OTHERWISE SPECIFIED
- PARTIAL REFERENCE DESIGNATIONS ARE SHOWN. FOR COMPLETE DESIGNATIONS, PREFIX WITH APPLICABLE UNIT NUMBER AND ASSEMBLY DESIGNATOR.
  - DEFINITIONS FOR SYMBOLS SHOWN ARE AS FOLLOWS:
    - ▲ INPUT FROM ANOTHER FIGURE
    - ▲ INPUT FROM SAME FIGURE
    - OUTPUT TO ANOTHER FIGURE
    - OUTPUT TO BOTH SAME AND ANOTHER FIGURE
    - OUTPUT TO SAME FIGURE
  - REFER TO TABLES 7-4, 7-5, AND 7-6 FOR CIRCUIT CARD LOCATIONS.
  - REFER TO TABLES 7-7, 7-8, AND 7-9 FOR CIRCUIT CARD TEST POINTS.
  - REFER TO POWER DISTRIBUTION FOR DC POWER AND GROUND CIRCUITS.
  - CIRCUIT SYMBOLS INCLUDE CARD LOCATION AND CIRCUIT PIN NUMBERS.
  - PINS 3, 4, 21, 22, 49, 50, 59, 70 OF 1138 AND PINS 3, 4, 21, 22 OF 1139 ARE ALL CONNECTED TO FORM A COMMON LINE TO THE CATHODES OF ALL DIODES SHOWN IN 1138 AND 1139 FOR THE SIGNAL WBLTEA1.

FO-23. Lamp Test Logic Diagram





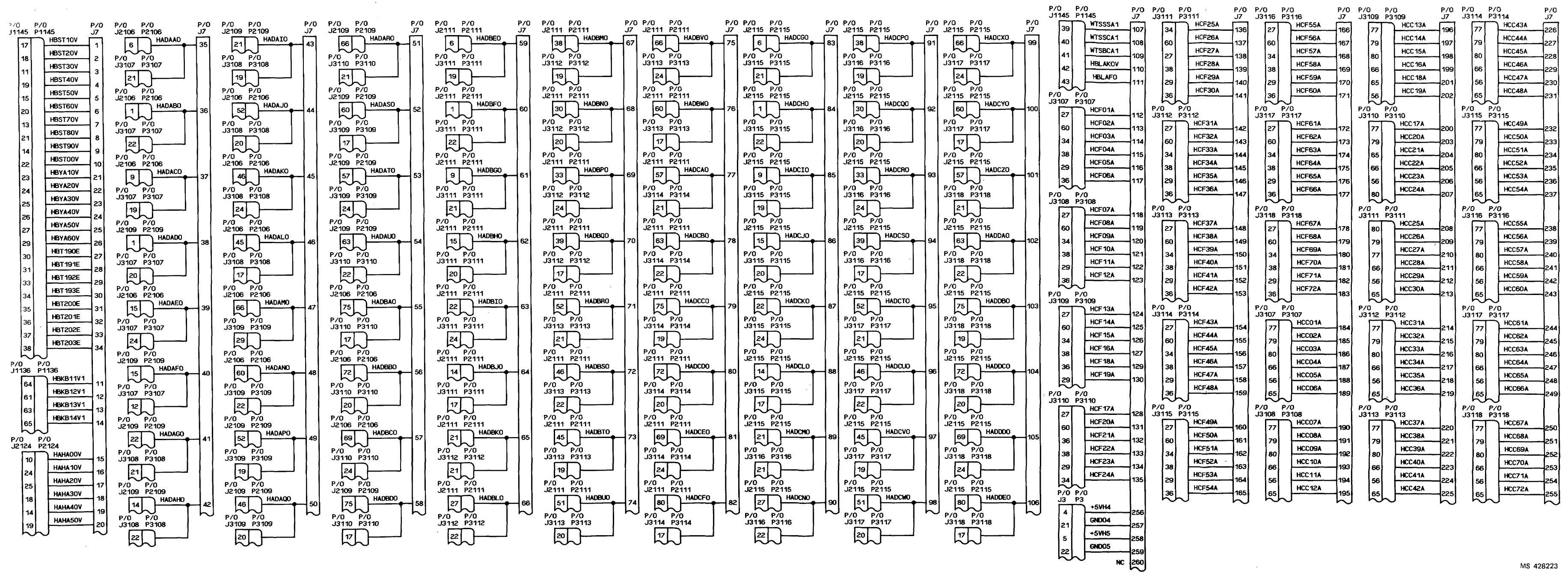

FO-24. Front Panel Schematic Diagram (Sheet 3 of 3)



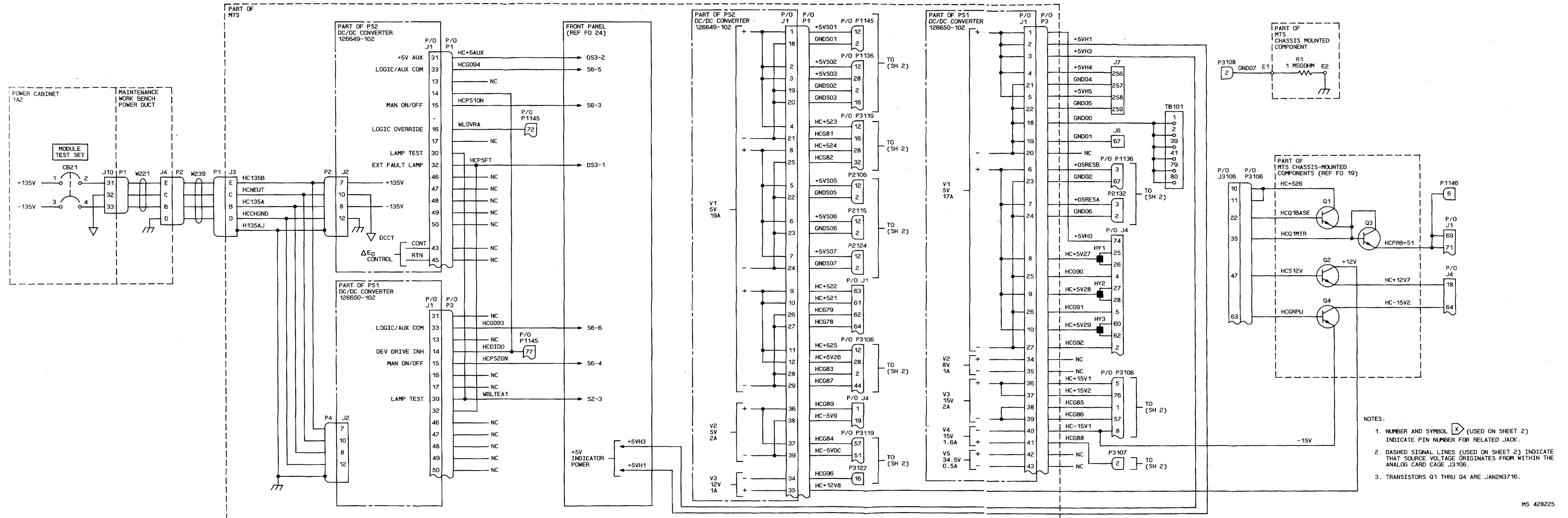

FO-25. Power Distribution Diagram (Sheet 1 of 2)









By Order of the Secretary of the Army:

E.C. MEYER  
*General, United States Army*  
*Chief of Staff*

Official:

Robert M. JOYCE  
*Major General, United States Army*  
*The Adjutant General*

Distribution:

To be distributed in accordance with DA Form 12-32, Section III, Organizational Maintenance requirements for AN/TSQ-73 Missile System.

\* U.S. GOVERNMENT PRINTING OFFICE: 1993 - 646-027/867 Region #4

RECOMMENDED CHANGES TO EQUIPMENT TECHNICAL PUBLICATIONS



THEN...JOT DOWN THE  
DOPE ABOUT IT ON THIS FORM.  
CAREFULLY TEAR IT OUT, FOLD IT  
AND DROP IT IN THE MAIL.

SOMETHING WRONG WITH PUBLICATION

FROM: (PRINT YOUR UNIT'S COMPLETE ADDRESS)

DATE SENT

PUBLICATION NUMBER

PUBLICATION DATE

PUBLICATION TITLE

BE EXACT PIN-POINT WHERE IT IS

PAGE  
NO.

PARA-  
GRAPH

FIGURE  
NO.

TABLE  
NO.

IN THIS SPACE, TELL WHAT IS WRONG  
AND WHAT SHOULD BE DONE ABOUT IT.

TEAR ALONG PERFORATED LINE

PRINTED NAME, GRADE OR TITLE AND TELEPHONE NUMBER

SIGN HERE

# THE METRIC SYSTEM AND EQUIVALENTS

## WEIGHT MEASURE

1 Centimeter = 10 Millimeters = 0.01 Meters = 0.3937 Inches  
 1 Meter = 100 Centimeters = 1000 Millimeters = 39.37 Inches  
 1 Kilometer = 1000 Meters = 0.621 Miles

## WEIGHTS

1 Gram = 0.001 Kilograms = 1000 Milligrams = 0.035 Ounces  
 1 Kilogram = 1000 Grams = 2.2 lb.  
 1 Metric Ton = 1000 Kilograms = 1 Megagram = 1.1 Short Tons

## LIQUID MEASURE

1 Milliliter = 0.001 Liters = 0.0338 Fluid Ounces  
 1 Liter = 1000 Milliliters = 33.82 Fluid Ounces

## SQUARE MEASURE

1 Sq. Centimeter = 100 Sq. Millimeters = 0.155 Sq. Inches  
 1 Sq. Meter = 10,000 Sq. Centimeters = 10.76 Sq. Feet  
 1 Sq. Kilometer = 1,000,000 Sq. Meters = 0.386 Sq. Miles

## CUBIC MEASURE

1 Cu. Centimeter = 1000 Cu. Millimeters = 0.06 Cu. Inches  
 1 Cu. Meter = 1,000,000 Cu. Centimeters = 35.31 Cu. Feet

## TEMPERATURE

$5/9(^{\circ}\text{F} - 32) = ^{\circ}\text{C}$   
 212° Fahrenheit is equivalent to 100° Celsius  
 90° Fahrenheit is equivalent to 32.2° Celsius  
 32° Fahrenheit is equivalent to 0° Celsius  
 $9/5^{\circ}\text{C} + 32 = ^{\circ}\text{F}$

## APPROXIMATE CONVERSION FACTORS

TO CHANGE	TO	MULTIPLY BY
Inches	Centimeters	2.540
Feet	Meters	0.305
Yards	Meters	0.914
Miles	Kilometers	1.609
Square Inches	Square Centimeters	6.451
Square Feet	Square Meters	0.093
Square Yards	Square Meters	0.836
Square Miles	Square Kilometers	2.590
Acres	Square Hectometers	0.405
Cubic Feet	Cubic Meters	0.028
Cubic Yards	Cubic Meters	0.765
Fluid Ounces	Milliliters	29.573
its	Liters	0.473
arts	Liters	0.946
allons	Liters	3.785
Ounces	Grams	28.349
Pounds	Kilograms	0.454
Short Tons	Metric Tons	0.907
Pound-Feet	Newton-Meters	1.356
Pounds per Square Inch	Kilopascals	6.895
Miles per Gallon	Kilometers per Liter	0.425
Miles per Hour	Kilometers per Hour	1.609

TO CHANGE	TO	MULTIPLY BY
Centimeters	Inches	0.394
Meters	Feet	3.280
Meters	Yards	1.094
Kilometers	Miles	0.621
Square Centimeters	Square Inches	0.155
Square Meters	Square Feet	10.764
Square Meters	Square Yards	1.196
Square Kilometers	Square Miles	0.386
Square Hectometers	Acres	2.471
Cubic Meters	Cubic Feet	35.315
Cubic Meters	Cubic Yards	1.308
Milliliters	Fluid Ounces	0.034
Liters	Pints	2.113
Liters	Quarts	1.057
ers	Gallons	0.264
ms	Ounces	0.035
ograms	Pounds	2.205
Metric Tons	Short Tons	1.102
Newton-Meters	Pounds-Feet	0.738
Kilopascals	Pounds per Square Inch	0.145
ometers per Liter	Miles per Gallon	2.354
ometers per Hour	Miles per Hour	0.621





**PIN: 052196-002**